

Automatic exhaust valve

Type ATVC-100

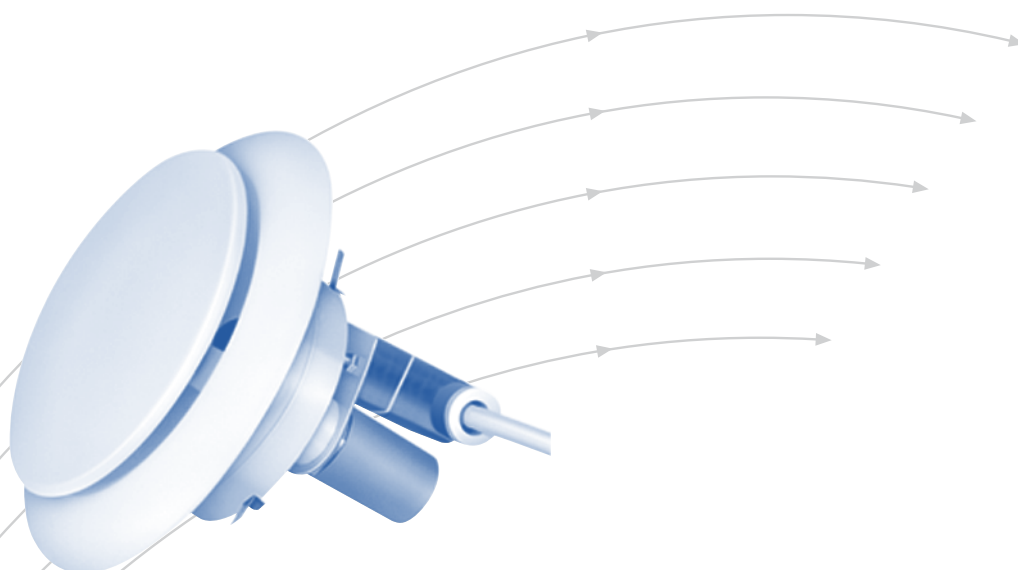

TROX[®] TECHNIK



TROX HESCO Schweiz AG
Walderstrasse 125
Postfach 455
CH - 8630 Rüti ZH

Tel. +41 (0)55 250 71 11
Fax +41 (0)55 250 73 10
www.troxhesco.ch
info@troxhesco.ch

Contents

| | |
|----------------------------------------------------|---------|
| Application · Realisation · Operating · Advantages | 2 |
| Dimensions · Installation | 3 |
| Installation | 4 and 5 |
| Technical Data | 6 |
| Order Details | 7 |

Application

Automatic exhaust valves type ATVC-100 are suitable for installations in multi-storey residential buildings, office blocks, hotels, schools etc., with a central exhaust air system. ATVC-100 can be installed either in new or renovated buildings.

Realisation

The automatic exhaust valve is an air control unit controlled by an electric pilot switch. It is normally closed or slightly open to allow a basic air flow rate. Air is extracted at a higher operating rate only when the switch contact is closed.

Operating

When the circuit is closed, the electro-thermal drive heats up and causes the valve disc to open within 2 to 4 minutes (delay desirable during a brief stay in the room). Air is exhausted through the opening between the valve housing and the valve disc. The valve stroke (6 mm) is always the same, that is, the valve disc always moves from the minimum setting up to the maximum valve opening. In the minimum setting, the valve disc can either be closed or opened. Since the valve stroke is always the same, the operating air flow rate depends on the minimum setting and cannot be freely selected. After the interruption of the circuit, the valve remains open for after-ventilation for approx. 5 - 8 minutes before it starts to move back to its minimum setting slowly and silently.

Advantages

- Heating energy can be saved thanks to controlled air flow (basic air volume rate/operating air volume rate).
- No high air volume rate during a brief stay in the room thanks to an in-built start delay).
- Exhaust valve opens and closes silently.
- Exhaust valve and electro-thermal drive constructed from well-proven components.
- Easy to install.
- Under the conditions of a simultaneity factor, roof ventilator and duct can be chosen smaller.
- The exhaust valve can be tightly closed.
- Can be connected to the lighting circuit 230V, 50Hz without a delay relay (sequent ventilation) or transformers.

Choice of unit

The valve is selected on the following data base:

- static pressure drop Δp_s (Pa)
- basic air volume rate \dot{V}_o (m³/h)
- operating air volume rate \dot{V} (m³/h)

The static pressure drop and only one of the two air volume rates can be freely selected. The following details can be found in the diagram:

- number of rotations
- residual air volume rate
- acoustic data

Please note that the respective operating air volumen rate characteristic must be taken into consideration in relation to the selected minimum setting.

Tested: splash water tested SEV

- 1 Valve housing
- 2 Valve disc
- 3 Electro-thermal drive
- 4 Tapper
- 5 Knurled nut
- 6 Electrical connection
- 7 Spring element (3 off)
- 8 Foam seal

Installation

Once the required air volume rate has been set (as described) and the electric position connected, the automatic exhaust valve can be introduced into the appropriate opening so that the housing is flush with the wall. The exhaust valve is held in the opening by means of 3 spring fastenings.

Technical characteristics

| | |
|-------------------------------|-------------|
| Nominal voltage: | 230V / 50Hz |
| Power consumption, operation: | 8W |
| Max. ambient temperature: | 30° C |
| Nominal diameter: | Ø100 mm |

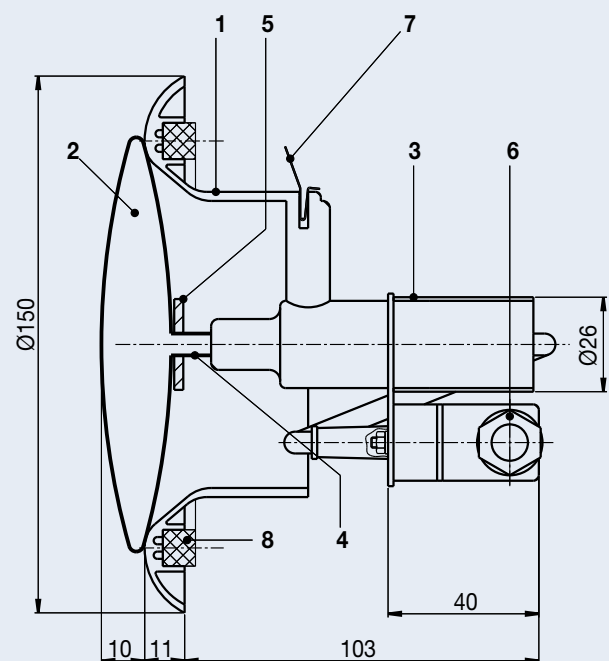

Installation

Adjusting of the basic air volume rate \dot{V}_0

- 1 Valve housing
- 2 Valve disc
- 3 Electro-thermal drive
- 4 Tappet
- 5 Knurled nut

The automatic exhaust valve is closed by delivery (basic air volume rate $\dot{V}_0 = 0 \text{ m}^3/\text{h}$).

To set the valve to the basic air volume rate, proceed as follows:

Place the exhaust valve on a firm base, e.g. a table, as shown and loosen the brass knurled nut «5» clockwise approx. by one rotation.

Hold the exhaust valve at the electric drive and, with one finger of the free hand, rotate the valve disc «2» anticlockwise by the required number of rotations.

Place the exhaust valve on a firm base such as a table as shown, hold it firmly with one hand against the base and tighten the knurled screw «5» anticlockwise to the tappet «4».

Important: It is important that during this operation the valve disc does not rotate.

The exhaust valve is now set.

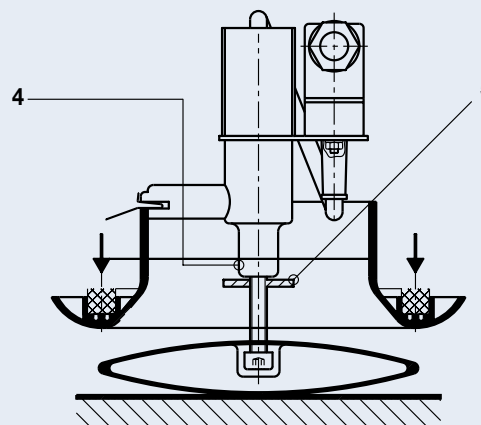
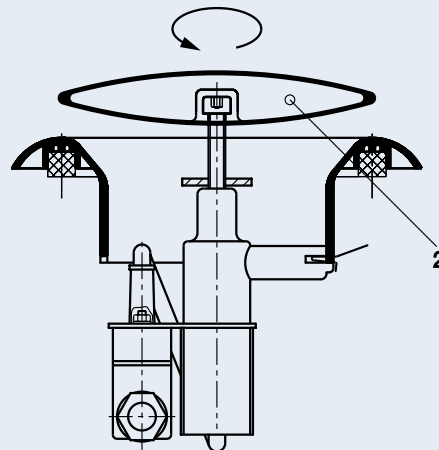
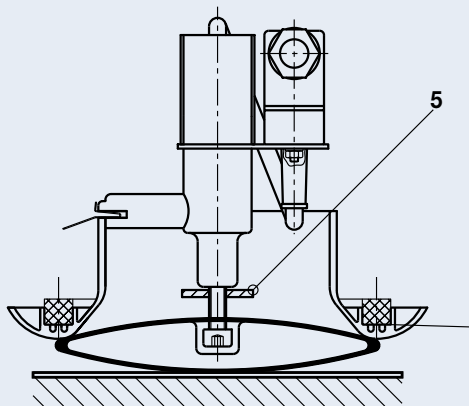
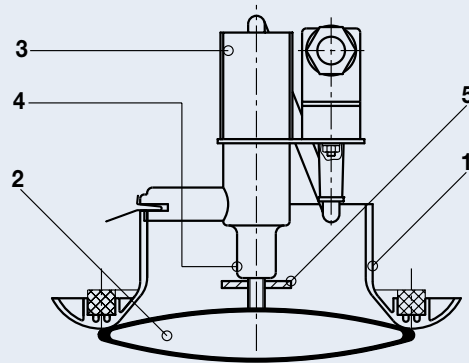

Electrical Connection

Location of the electric cable

It is best to lead the cable into the round air exhaust ducting.

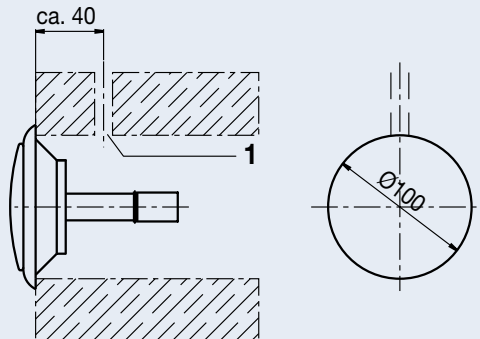

Plastic tube (e.g. KRF 11), position: side or top

Plug «A» can be removed from the plate «C» after removing the central screw «B». With the central screw «B» removed from the plug «A», the insert «F» can be forced out with a screw-driver at the point marked «D».

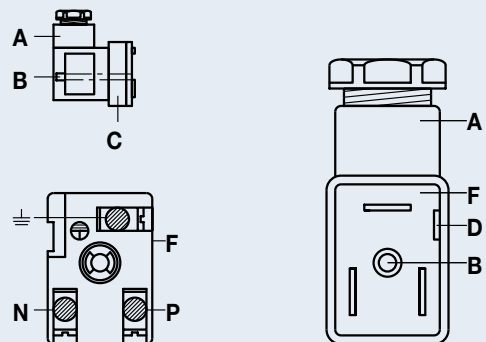

Connection diagram

P = Phase conductor

N = Neutral

E = Earth

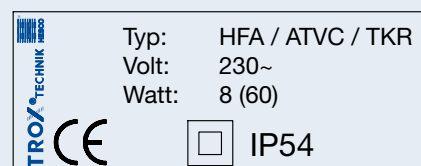
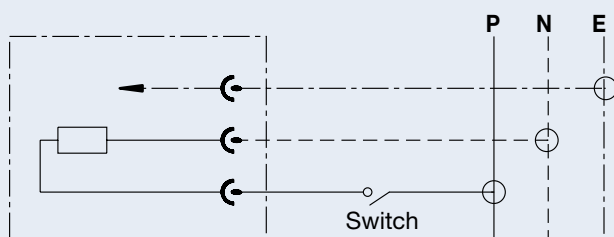

EC, SEV approval, specially-insulated equipment with splash-protection.

Technical Data

Definitions

- L_{wA} dB(A) = Sound power level (tolerance ± 2 dB)
- \dot{V}_o m³/h = Basic air volume rate
- \dot{V} m³/h = Operating air volume rate
- Δp_s Pa = Pressure drop
- n = Rotations at the disc
- 0** = Works setting (closed)
- 1 - 4** = Minimum settings 1 - 4 rotations

Example (as plotted)

- Given**
- Static pressure drop $\Delta p_s = 40$ Pa
 - Operating air volume rate $\dot{V} = 80$ m³/h

Solution

- Number of rotations for minimum setting 1
- Basic air volume rate $\dot{V}_o = 10$ m³/h
- Sound power level for:

| | |
|-----------------------------------|------------|
| Basic air volume rate | < 25 dB(A) |
| Operating air volume rate approx. | 38 dB(A) |

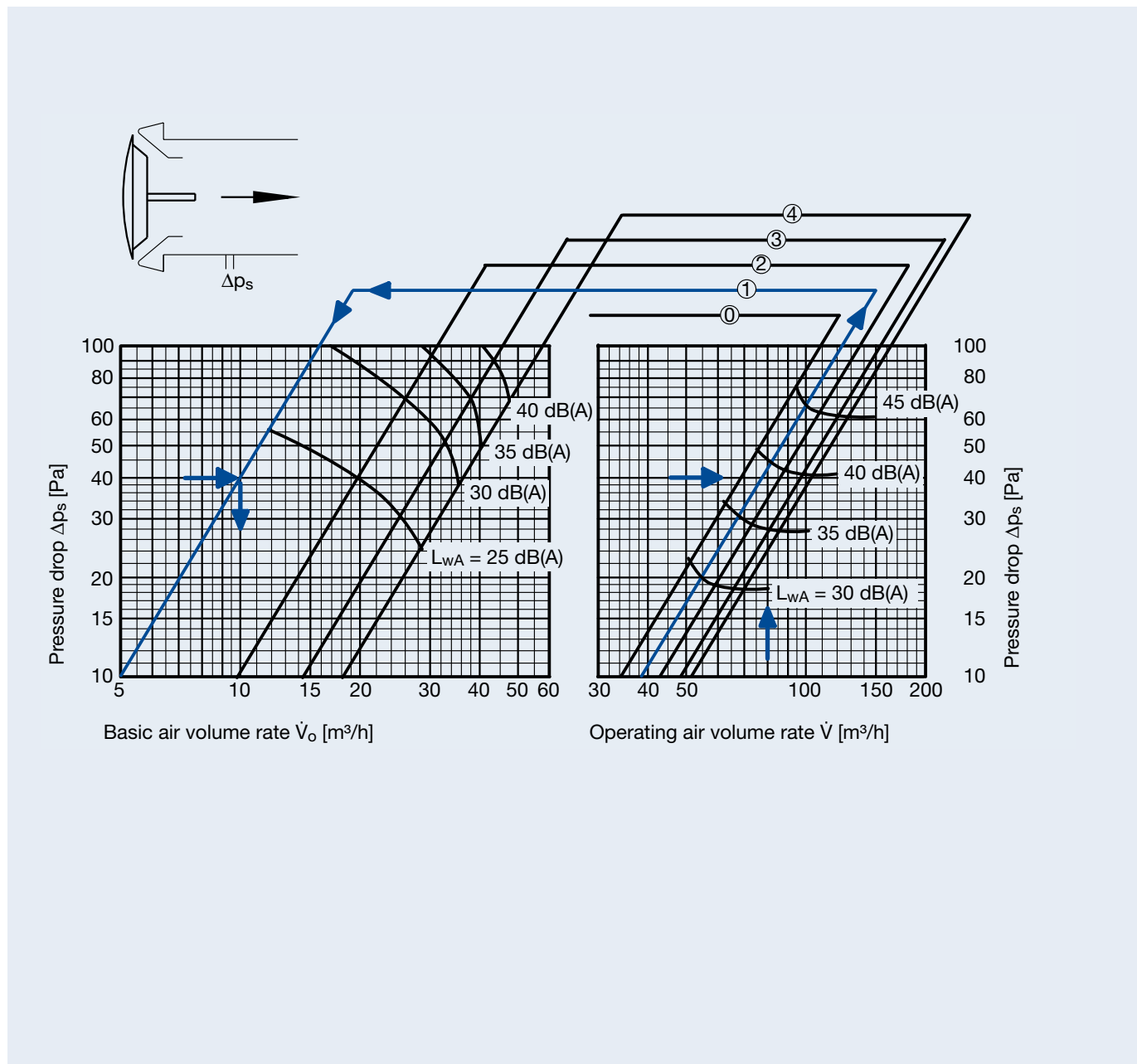

Order codes

No details for standard products

ATVC-100 / 0 / 0 / 0 / S1

Type

Automatic exhaust valve type ATVC-100

0 = white plastic (standard)

S1 = Spray painted according to RAL (all RAL colours and brilliance on request)

Order example

20 off ATVC-100/S1/RAL9006

10 off ATVC-100

Text for tendering purposes

Automatic exhaust valve brand type ATVC-100 with electro-thermal drive, for connecting 230V / 50Hz mains, adjustable air volume rate, for exhaust air systems, SEV tested.

