

# TKM 50 N

## Quality and Technology in Air Handling

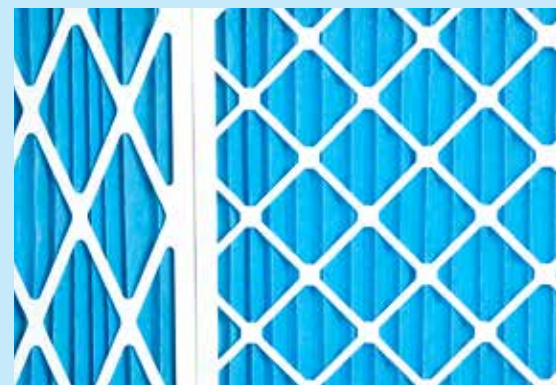

**TROX<sup>®</sup> TECHNİK**  
The art of handling air

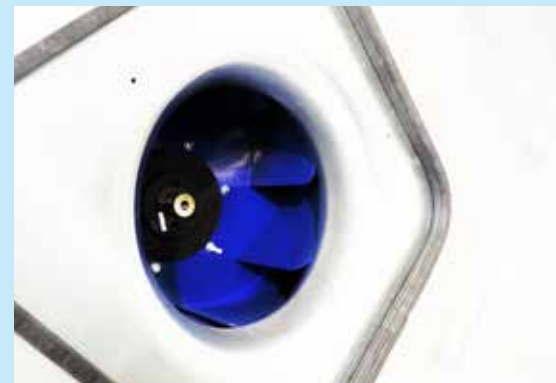

## ► The art of handling air ►►

**TROX is leader in the development, manufacture and distribution of ventilation and air-handling systems.**

Founded in 1951, the TROX GROUP now has 34 subsidiaries distributed over 5 continents, 20 production plants, as well as importer agents and representatives in more than 70 countries. The group's current turnover exceeds 530 million Euros and has more than 4,560 staff members.

Within what is known as the one-stop shop strategy: **TROX offers a comprehensive solution.** A broad and varied portfolio of systems and components adapted to every project, and its first-rate customer and technical support services, make TROX the ideal partner when undertaking the development of any project, regardless of its scale and application.

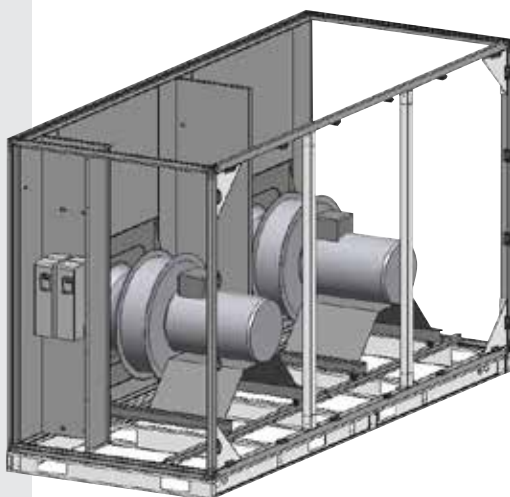

TROX TKM 50 air-handling units set a milestone in the history of national air-handling manufacturers, since it is the first air-handling series manufactured in Spain with EUROVENT certification.



## Tailored to the Customer and the Project

The TKM 50 N units have been designed for air flows of up to 100,000 m<sup>3</sup>/h, with the usual range of sections found in these types of units.

They are built with a painted, extruded-aluminium self-supporting frame with injected-aluminium corners.

Sandwich-type panels (50 mm) whose outer plate has Magnelis® rust protection; the inner galvanised-steel plate, with mineral-wool insulation, has Class-A1 fire resistance.

Each module is supported on a socket formed from U-type galvanised steel sheet, cold-rolled profiles.

These units are tailor-made, adapted to the needs of both the customer and the project, thus providing an optimum solution for projects of any typology. All their components meet the quality standards that the TROX brand demands from its suppliers.

The technical specifications of their casings make them ideal for a wide variety of installations, such as:

- Administration buildings
- Hotels
- Hospitals
- Education centres
- Sports centres
- Shopping centres, etc...

TROX España has been manufacturing air-handling units since 1987 and, up till now, more than 28,000 units have been supplied for all kinds of projects and applications.

**Air-handling units** are designed using CAD 3D; this allows us to validate the product, its sections and components before manufacture, without the need to use prototypes. In turn, this gives us additional time for custom-designing the units, using the portfolio of models developed for previous projects.

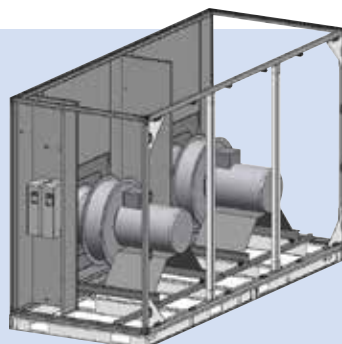

All units are configured meeting each project's specific demands. They are configured and designed using software.



This tool takes into account the energy-efficiency requirements set forth in the Ecodesign Directive and, therefore, guarantees their correct configuration.

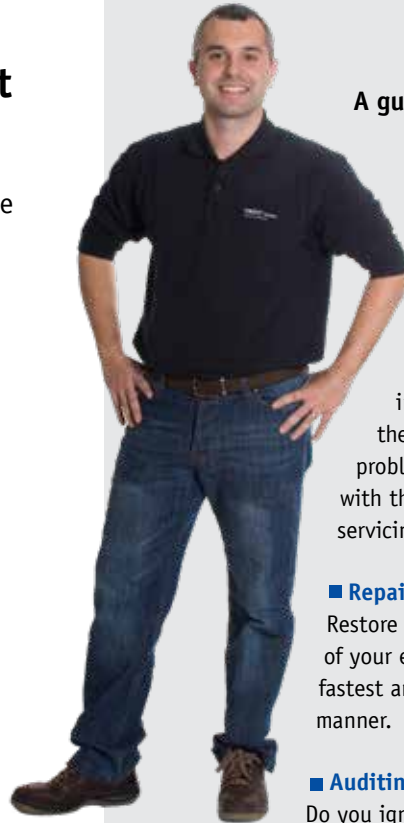

**A guarantee for fast and efficient responses**

### ■ Commissioning

Ensure the correct operation of the units in accordance with the project, and prevent problems by entrusting TROX with the commissioning and servicing of the equipment.

### ■ Repairs

Restore the perfect operation of your equipment in the fastest and most efficient manner.

### ■ Auditing

Do you ignore how your equipment is operating?

Would you like to use it in different operating conditions, but do not know if the unit allows it? TROX's Technical Support Department can audit the unit's operation on site by performing all the necessary measurements, and issuing a report with appropriate recommendations and proposals for improvement.

### ■ Product upgrades

Extend the useful life of your equipment and improve its energy efficiency by renewing its components with TROX's assistance. For example, performance can be improved up to 30% just by replacing the fans with cutting-edge models.

### ■ Unit assembly on site

Is the space on-site limited for the transportation and placement of air-handling units?

TROX can supply the equipment completely disassembled for easy transportation; then, our technicians can assemble it on-site until the unit is operational, as if it had just left the factory.

### ■ Maintenance

Ensure long-term operation thanks to TROX's maintenance professionals.

[sat-es@troxgroup.com](mailto:sat-es@troxgroup.com)



© TÜV SÜD



## Present and Future of AHUs

Traditionally, the main function of air-handling units was to provide facilities with clean, treated air, and with certain temperature and humidity conditions.

Nowadays, air-handling units must be able of performing the same functions, but with the least possible energy consumption. Furthermore, in most cases, energy-recovery systems should be in place. Ultimately, they must be energy efficient.

In order to achieve energy efficiency in the units, the point of departure should be a high-quality casing that can reduce the amount of heat energy wasted (thermal transmission and thermal bridge), and maximise the casing air tightness, thus minimising both the untreated-air input and the treated-air output.

Furthermore, it is necessary to ensure that the unit's casing can resist deformities caused by the overpressure and underpressure generated by the fans (mechanical resistance).

These points are defined and classified in standard EN-1886.

### ■ EN-1886

EN-1886 is the European standard responsible for evaluating the mechanical features of the casings in air-handling units. More specifically, it includes:

- Mechanical resistance
- Air tightness
- Air leak flow due to bleeding through the filter wall
- Thermal transmission
- Thermal bridge
- Acoustic insulation

### Mechanical Resistance of the Casing

In line with the instructions given in standard EN-1886:2007, the unit is subjected to an overpressure of 1,000 Pa, and then an underpressure of 1,000 Pa, in each case measuring the maximum bend produced on the structure.

Lastly, the unit is subjected to an overpressure of 2,500 Pa and an underpressure of 2,500 Pa, before checking the structure for permanent deformities.

The TKM 50 N series obtains values of 4.5 mm/m in the +1,000 Pa test, and 0.2 mm/m in the -1,000 Pa test, which corresponds to overpressure/underpressure class D2 (since the most restrictive value prevails).

Mechanical Resistance of the Casing		
Limit	EN-1886:1998	EN-1886:2007
4 mm/m	2A	D1(M)
10 mm/m	1A	D2(M)
>10 mm/m	1B	D3(M)

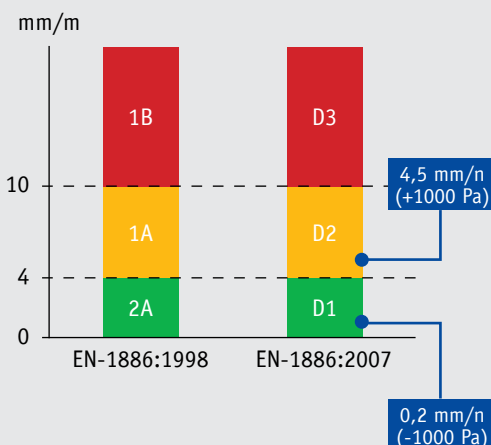

## Air Tightness of the Casing

According to Standard EN-1886, the leak test must be performed after the mechanical resistance test. It begins by subjecting the unit to an underpressure of 400 Pa, and measuring the air leak flow rate through the casing, and then, repeating the process and subjecting the unit to an overpressure of 700 Pa.

The TKM 50 N series obtains air leak flow rates of  $0.02 \text{ dm}^3/(\text{s} \cdot \text{m}^2)$  in the -400 Pa test, and  $0.03 \text{ dm}^3/(\text{s} \cdot \text{m}^2)$  in the +700 Pa test, which correspond to the maximum classification possible, L1.

Air tightness of the casing			
Pa	Limit $\text{dm}^3/(\text{s} \cdot \text{m}^2)$	EN-1886:1998	EN-1886:2007
-400	0,15	B	L1
	0,44	B	L2
	1,32	A	L3
	>1,32	3A	
+700	0,22	B	L1
	0,63	B	L2
	1,90	A	L3
	5,70	3A	

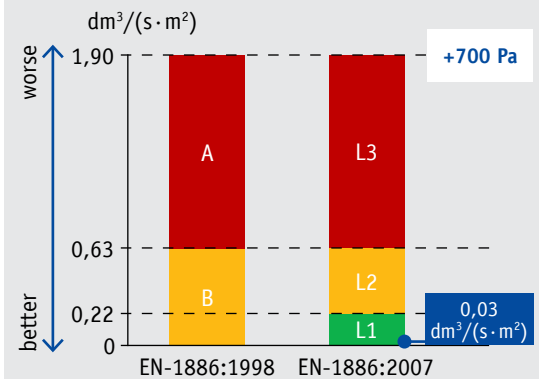
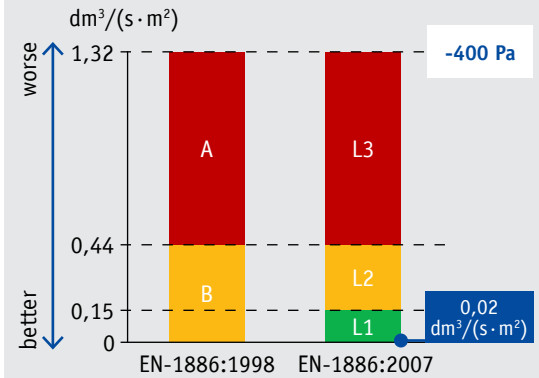

## Air-Leak Flow Rate Due to Bleeding Through the Filter Wall

As indicated in Standard EN-1886, the air leak flow rate due to bleeding through the filtration wall reduces filter efficiency, particularly in the case of a high-efficiency filter, because the leaking air is not filtered.

During the test, the unit is subjected to an overpressure and an underpressure of 400 Pa, and the percentage of air flow that does not pass through the filter cells is measured in relation to the rated value.

The TKM 50 N series obtains leak flow rates of 0.1% in the +400 Pa test, and 0.1% in the -400 Pa test, which corresponds to the maximum classification possible, F9.

Air leak flow due to bleeding through the filter		
Limit	EN-1886:1998	EN-1886:2007
0,5 %	F9	F9
1,0 %	F8	F8
2,0 %	F7	F7
4,0 %	F6	F6

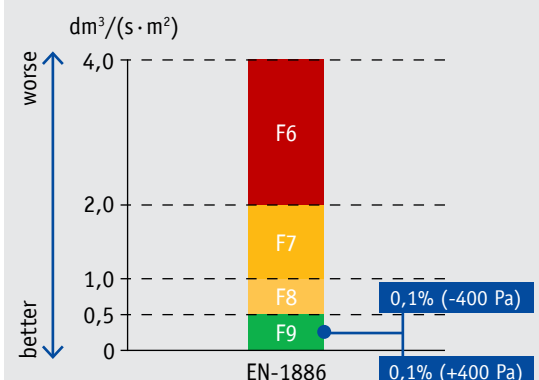

Thermal transmission		
Limit	EN-1886:1998	EN-1886:2007
$U \leq 0,5 \text{ W}/(\text{m}^2 \cdot \text{K})$	T1	T1
$U \leq 1,0 \text{ W}/(\text{m}^2 \cdot \text{K})$	T2	T2
$U \leq 1,4 \text{ W}/(\text{m}^2 \cdot \text{K})$	T3	T3
$U \leq 2,0 \text{ W}/(\text{m}^2 \cdot \text{K})$	T4	T4

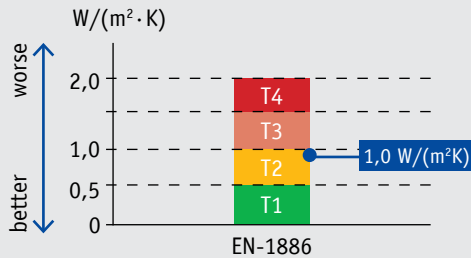

Thermal bridge		
Limit	EN-1886:1998	EN-1886:2007
$K_b > 0,75$	TB1	TB1
$K_b > 0,60$	TB2	TB2
$K_b > 0,45$	TB3	TB3
$K_b > 0,30$	TB4	TB4

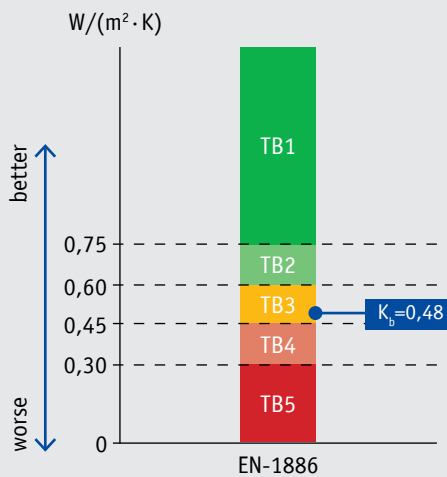

Frequency band (Hz)						
125	250	500	1,000	2,000	4,000	8,000
Acoustic insulation of the casing (dB)						
15	23	29	30	23	29	45

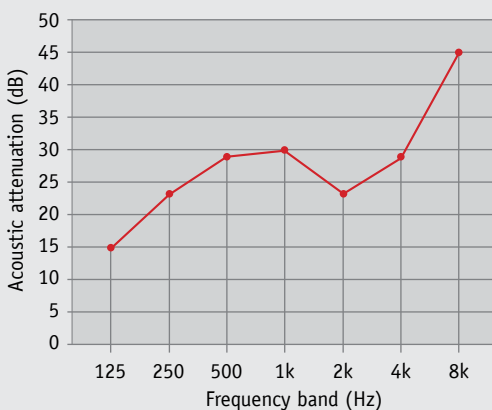

## Thermal Transmission

According to Standard EN-1886, the thermal transmission  $U$  ( $\text{W}/\text{m}^2 \cdot \text{K}$ ), must be obtained when the temperature difference under stable conditions between the inside and the outside of the unit is 20 K. The surface used to calculate the value of  $U$  must correspond to the external surface of the casing (without the base frame and the upper ceiling, e.g. the weather cover installed on units for outdoor use).

The TKM 50 N series obtains a thermal transmission coefficient  $U = 1.0$  ( $\text{W}/\text{m}^2 \cdot \text{K}$ ), which is classified as Class T2.

## Thermal Bridge

According to EN-1886, under test conditions when the difference in average temperature between the interior and exterior temperatures is steady at 20 K, the point at the highest temperature on the outer surface of the casing must be obtained. The ratio between the temperature difference between the interior and the maximum surface temperature, and the average temperature difference between the air on the interior and exterior of the unit determines the thermal bridge factor.

$$k_b = \Delta t_{\text{tmin}} / \Delta t_{\text{air}}$$

Where:

$\Delta t_{\text{tmin}}$ : is the smallest temperature difference

$$\Delta t_{\text{tmin}} = t_i - t_{\text{smax}}$$

$\Delta t_{\text{air}}$ : is the temperature difference between the interior and exterior air

$$\Delta t_{\text{air}} = t_i - t_a$$

$t_i$ : is the average air temperature on the interior of the unit

$t_a$ : is the average air temperature on the exterior of the unit

$t_{\text{smax}}$ : is the maximum temperature on the exterior surface of the unit

The TKM 50 N obtains a thermal bridge factor:

$k_b = 0.48$  which classifies it within the TB3 Class

## Acoustic Insulation of the Casing

Thanks to the type of insulation used on the panels, and the excellent air tightness of the casing, the TKM 50 N series casing obtains the acoustic attenuation values indicated in the enclosed graph.

## ■ CE Marking

The TKM 50 N series units have been designed and manufactured according to the essential requirements of applicable European Community directives:

- Directive 2006/42/EC, machinery directive
- Directive 2014/35/EC, on the approximation of the laws of Member States relating to electrical equipment designed for use within certain voltage limits
- Directive 2014/30/EC, on electromagnetic compatibility
- Directive 2009/125/EC, on ecodesign requirements for energy-related products

The harmonised standards used for its design are:

- EN ISO 12.100.1
- EN ISO 12.100.2

## ■ Mechanical Safety

The TKM 50 N series units are compliant with the European Community directives on machine safety, including:

- Safety device on doors located in positive pressure (overpressure) areas
- Casing earthing system to avoid risks of accidents
- Belt covers on units fitted with belt-pulley transmission fans
- Hazard signs in areas where there are moving parts or high temperatures
- Protection grille on the inlets of fans with transmissions
- Handles with a key lock in accesses to fans and electrical coils
- Handles with a key lock in sections where there is a risk of high temperature

## ■ Environment

The TKM 50 N meet the requirements defined by Standard EN1886 and are adapted to the RITE (Regulation on Thermal Installations in Buildings) in terms of ventilation, free cooling, recovery of extracted air, and motor and fan efficiency.

This series is the most suitable for compliance with the new European energy efficiency directive (2010/31/EU) that sets the minimum energy efficiency in buildings, and describes nearly zero energy consumption buildings.



In compliance with the demands of these directives, we are allowed to use the CE marking on our units, and provide the corresponding EC Declaration of Conformity with all of them.

Furthermore, all of the components of our units that are affected by these directives will have the corresponding CE marking of their manufacturer.



Handle with a key lock to increase the security of the units in compliance with CE marking.



Example of an energy classification label for buildings in Spain, where the scale and the classification obtained can be clearly seen.

## A Construction that Offers Multiple Variants



### Magnelis® exterior sheet

High corrosion resistant. Finish in RAL 7035 colour.



### Exterior hinges

Enabling the access doors to be opened 180°.



### Doors and access covers

Equipped with fast-opening handles for easier interior access. They are fitted with a key lock to meet the CE marking requirements.



### Connecting parts

Simple, precise connection between modules.



### Panels and profiles

Simplified maintenance thanks to the flush mounting of panels and profiles, both on the interior and exterior of the units.



### Frame

Made of pre-lacquered aluminium, with injected-aluminium corners.



### Robust platform model

With holes for module lifting and handling.



### Panels

The panels are fitted with mineral wool acoustic and thermal insulation.



### Inspection windows

The access doors include large sight windows for easier interior inspection.





## Dampers

Multi-slat, aerodynamic-profile dampers to control the air flow. Several units can be combined to provide a mixing or free-cooling section.



## Acoustic attenuation

The acoustic attenuation section is formed by TROX silencer cells that offer a very low load loss and great damping of the fan's sound spectrum.



## Recovery systems spectrum

Wide spectrum of rotary, static or coil recovery systems that adapt to the heat recovery requirements of the facilities.



## Frequency converter

To provide the facilities with the flow of air required at any given time. This offers greater energy savings by adapting motor consumption to the true needs of the facilities.

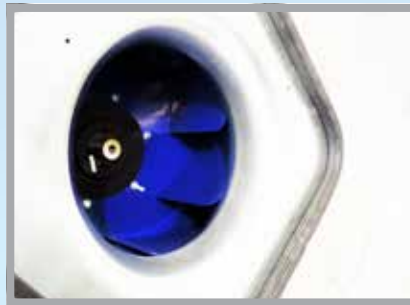

## Fans

Plug-fans with a turbine made of aerodynamic profile slats connected directly to three-phase motors or EC motors. Optionally, they can be fitted with double-inlet centrifugal fans with a transmission.



## TROX CONTROL System

Air-handling units are fitted with controls which regulate and monitor components in real time, thus allowing for the integration of the building management system (BMS) into the centralised system via different protocols (ModBus, BACnet, LONWorks...).



## Interior lighting

Access sections may include interior lighting for easier cleaning and maintenance work.



## Coils for cooling and heating

Made of copper tubes and standard aluminium fins. Optionally, coils may have special treatments against corrosion.



## Minipleat filters with EUROVENT Certification

With low load loss and high dust-accumulating capacity. Filtering rating from M5 to F9, ISO ePM10( $\geq 50\%$ ) and ISO ePM1( $\geq 80\%$ ), respectively.

The selection of TKM 50 N air-handling units is made via YAHUS by TROX.



The YAHUS tool simplifies the configuration, design and calculation tasks for the units.

The configuration and design program for the air-handling units is an essential tool for guaranteeing the reliability and the features of the selected units. Furthermore, it is a fundamental tool for making engineering projects. Therefore, it is constantly subject to improvements.



The image shows Toledo hospital (under construction), one of the buildings where TROX España has supplied this air-handling series.

We would like to highlight the following projects implemented to date:

- Sampath Bank Center (India)
- Renault Factory in Palencia (Spain)
- Airbus in Getafe (Spain)
- Salamanca Hospital (Spain)
- Catalana Occidente Corporate Headquarters (Spain)
- Oran Hotel School (Algeria)
- Hospital del Sur in Quito (Ecuador)
- San Bernardo Sports Centre, Seville (Spain)
- among others.

## Your Air Handling Unit Software by TROX

The TKM 50 N series of air-handling units are configured, calculated and selected using the YAHUS by TROX software.

YAHUS has a simple-interface designed for selecting components more easily using intuitive, drop-down menus. It provides a graphic representation of fans, and psychrometric charts for the humidification, coil and energy recovery system processes. It runs on the Windows operating system.

Main features:

- Calculation and configurations through the use of predefined or user-customised templates.
- Real-time design using exterior and interior measurements to scale.
- Export of diagrams to '.dxf' format.
- Multiple air-handling unit views.

Latest developments:

- Compliance update with ErP regulations.
- Selection of new, more efficient ranges of AC and EC plug-fans.
- Fan configuration in a Fan-Array layout, as a wall of fans.
- Selection of coil recovery systems (Run-Around), with performance indicators.
- New types of silencer cells to adapt to specific acoustic needs.
- It allows fans to be configured with non-standard electrical voltages.
- It includes static and rotary recovery systems.
- Final filters with side-extraction system and air-tight frames.
- Control system definition.
- Exporting BIM files in Revit, integrated technical data.
- Possibility of selecting control and electrical panel.
- Selection of different-height units allowed.

Any requests for the YAHUS by TROX software – and any updates – are arranged over the TROX España website: [www.trox.es](http://www.trox.es), in the Product/Software section, by e-mail to the sales office responsible for your area.

## EUROVENT-certified EU model

The TKM 50 N EU series is EUROVENT certified.

With this certification, the facilities can guarantee that the units they have installed will work according to the specifications given in their design, and their operational energy costs meet the initial forecast at all times.

TROX offers all section sizes for the TKM 50 N range executed with EU certifications up to 100,000 m<sup>3</sup>/h flow rates.

This series comprises a pre-lacquered aluminium self-supporting frame with injected-aluminium corners.

The end panels are sandwich-type with Magnelis® corrosion-protection exterior sheet, and galvanised-steel interior sheet with 50 mm thick mineral wool intermediate insulation, and a perimeter seal. The doors are made in the same manner as the panels and are fitted with hinges and fast-opening handles. The panels are mounted flush to the frame – on both the interior and exterior of the unit – to create flat surfaces for easier cleaning and maintenance. Each module is supported on a socket formed from U-type galvanised steel sheet, cold-rolled profiles.

EUROVENT classification according to Standard EN-1886:

- Casing resistance (D2)
- Casing air tightness (L1)
- Leakage through filter (F9)
- Thermal transmission (T2)
- Thermal bridge (TB3)

Frequency band (Hz)						
125	250	500	1.000	2.000	4.000	8.000
Acoustic insulation of the casing (dB)						
15	23	29	30	23	29	45

TROX's versatility enables it to configure and manufacture fully-customized units that cannot be configured using YAHUS EU, and always with the same construction in order to guarantee classification according to EN-1886.

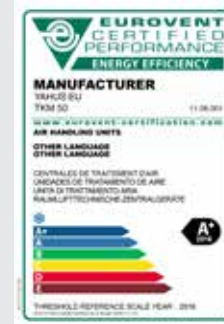

The selection of TKM 50 N EU units is made via YAHUS EU by TROX.



Example of selecting a EUROVENT-certified TKM 50 N EU unit fitted with a rotary recovery system.



# TROX<sup>®</sup> TECHNIK

The art of handling air

**TROX España**  
Pol. Ind. La Cartuja  
50720 Zaragoza - Spain  
Tel: 34 976 50 02 50  
trox-es@troxgroup.com  
www.trox.es