

Monitoring systems

Type TFM-2-TPM



For the monitoring of differential pressure, volume flow rate or face velocity

Monitoring system for measuring variables from an external transducer

- Areas of application: Monitoring of differential pressure in rooms or ducting, of volume flow rates, and of the face velocity on fume cupboards
- Connection of voltage signals 0 – 10 V with characteristics that can be set individually
- Monitoring of two independent values; the corresponding types of alarm can be set
- Optical and acoustic alarms are emitted on the control panel
- Power failure is displayed on the control panel
- Monitoring parameters and additional functions can be adjusted using MConnect configuration software
- For new installations and for refurbishment

Recording of the measured value to be monitored

- Face velocity transducer VS-TRD
- Differential pressure transducer with voltage signal
- Volume flow rate transducer with voltage signal

Type		Page
TFM-2-TPM	General information	2.2 – 8
	Special information – TFM-2	2.3 – 10
	Special information – TPM	2.3 – 12
	Specification text	2.3 – 14
	Basic information and nomenclature	2.7 – 1

2

Description



Monitoring system
TFM-2/TPM

Application

- Monitoring devices Type TFM-2-TPM for volume flow rates, face velocity or room differential pressure with optical and acoustic alarms and alarm signalling to higher-level systems (central BMS)
- Selection of type of monitoring (volume flow rate, face velocity, differential pressure) with a single unit, configurable
- Measuring with transducers (to be provided by others) that transform measured value into an electric signal
- For use in laboratories, clean rooms in the pharmaceutical and semiconductor industries, operation theatres, intensive care units
- For new installations, retrofit, and refurbishment projects

TFM-2

- Monitoring of the volume flow rate of fume cupboards, fume hoods, extraction arms to EN 1475; as an alternative, for the monitoring of volume flow rates in ducting
- Monitoring of the face velocity for fume cupboards, fume hoods
- Electric actual value signal, for example from a volume flow controller (to be provided by others) or face velocity transducer

TPM

- Monitoring of the differential pressure in rooms or ducting
- Electric actual value signal, for example from a room pressure transducer (to be provided by others) or balance ring manometers

Useful additions

- VS-TRD: Face velocity transducer for the LABCONTROL system
- EasyConnect: Configuration software for the commissioning and diagnosis of EASYLAB components
- Differential pressure transducers: Static differential pressure transducers for room pressure control or duct pressure control

Special features

- Monitoring of volume flow rate, differential pressure or face velocity
- Measurement recording with transducer (to be provided by others) as 0 – 10 V signal
- Two values can be monitored, switching between the two is possible; alarms can be configured; monitoring can be switched off

- Optical and acoustic alarms are emitted on the control panel
- Signalling of normal operation, measured value higher or lower than setpoint, power failure
- Conventional alarm signalling (switch contact) to the central BMS
- On-site configuration with free-of-charge configuration software MConnect

Parts and characteristics

- Microprocessor system with programme and system data stored in nonvolatile memory
- Double-stack terminal blocks for supply voltage connection
- 3 digital inputs with clamp terminals
- 4 digital outputs with clamp terminals
- 1 analog input with clamp terminals
- RJ socket for control panel
- Fuse
- Integral power failure recognition with maintenance-free Goldcap capacitor

Control panel

- Display: Volume flow rate or differential pressure alarm, red; power failure, flashing red
- Display: Normal operation, green
- Display: Volume flow rate exceeds setpoint or differential pressure deviates from setpoint, yellow
- Alarm acknowledgement
- Button to switch lighting on/off (only TFM-2)
- Alarm sounder
- Socket to connect a notebook for service and commissioning

Construction features

- Casing can be opened and closed without tools
- Control panel with plug-in connecting cable

Materials and surface

- Casing made of galvanised sheet steel, powder-coated, white
- Control panel made of plastic, light grey
- Control panel with front plastic (background HKS 91 30 %, buttons and text HKS 88 30 %)

Installation and commissioning

- Install the monitoring device
- Mount the control panel
- Attach sticker for TFM-2 or TPM to the control panel
- Connect measuring transducer to the monitoring device
- Set all monitoring parameters using MConnect
- Test monitoring functions

Technical data

Supply voltage	24 V AC ± 15 %, 50/60 Hz
Power rating	3.5 VA
Operating temperature	10 – 40 °C
Analogue input for sensor	0 – 10 V DC, characteristic can be configured
Switch rating of relays	250 V AC, 5 A
IEC protection class	III (protective extra-low voltage)
Protection level	IP 20
EC conformity	EMC to 2004/108/EG, low voltage to 2006/95/EG
Dimensions (B × H × T)	Main unit: 261 × 210,5 × 84 mm, control panel: 150 × 23 × 10 mm
Weight	1.6 kg

Order code

TFM-2-TPM

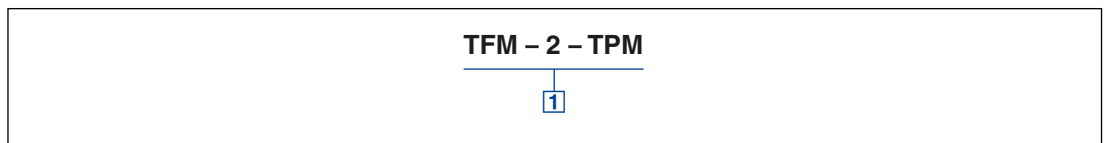

1 Type

TFM-2-TPM Monitoring system

Description

Application

- Monitoring of the volume flow rate of fume cupboards, fume hoods, extraction arms to EN 1475; as an alternative, for the monitoring of volume flow rates in ducting
- Monitoring of the face velocity for fume cupboards, fume hoods
- Electric actual value signal, for example from a volume flow controller (to be provided by others) or face velocity transducer

The correct aerodynamic function of a fume cupboard must be monitored and displayed (EN 14175-2, for refurbishment projects DIN 12924 may apply). Any fault must be indicated by an optical alarm and an alarm sound.

Function

Functional description

The volume flow rate is measured using a volume flow measuring unit or a VAV terminal unit. For face velocity monitoring a face velocity transducer can be connected.

During commissioning with the MConnect configuration software a constant that depends on the duct size is saved. This constant is used to calculate the volume flow rate actual value. The volume flow rate and differential pressure values are also set using MConnect.

The monitoring system considers a minimum value and a maximum value (switching, e.g. from daytime to night-time operation). Separate alarms

can be configured in case the actual value exceeds the setpoint or falls short of the setpoint.

- Alarm delay
- Duration of the alarm sounding; sound can also be suppressed

Alarm signalling to the central BMS can be achieved by wiring the alarm relay. The operating state is displayed on the control panel; optical and acoustic alarms are also emitted on the control panel. Room occupants can acknowledge alarms on the control panel. Depending on the setup the fume cupboard lighting can be switched on/off from the control panel. The monitoring system can be switched off.

Functional diagram

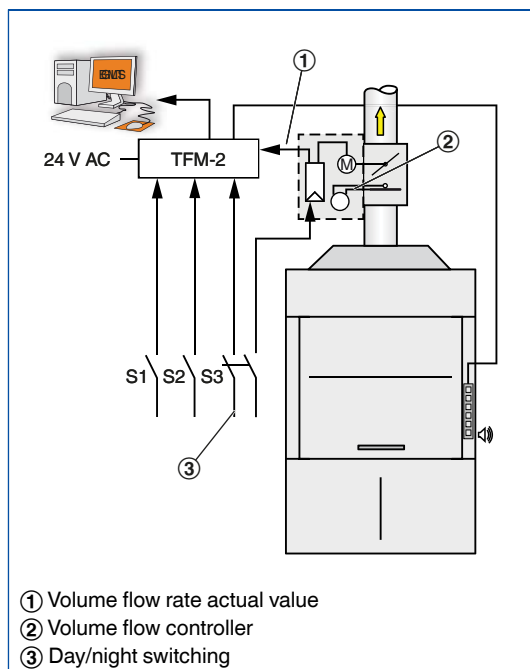

Function

Control panel for monitoring systems TFM-1 and TFM-2

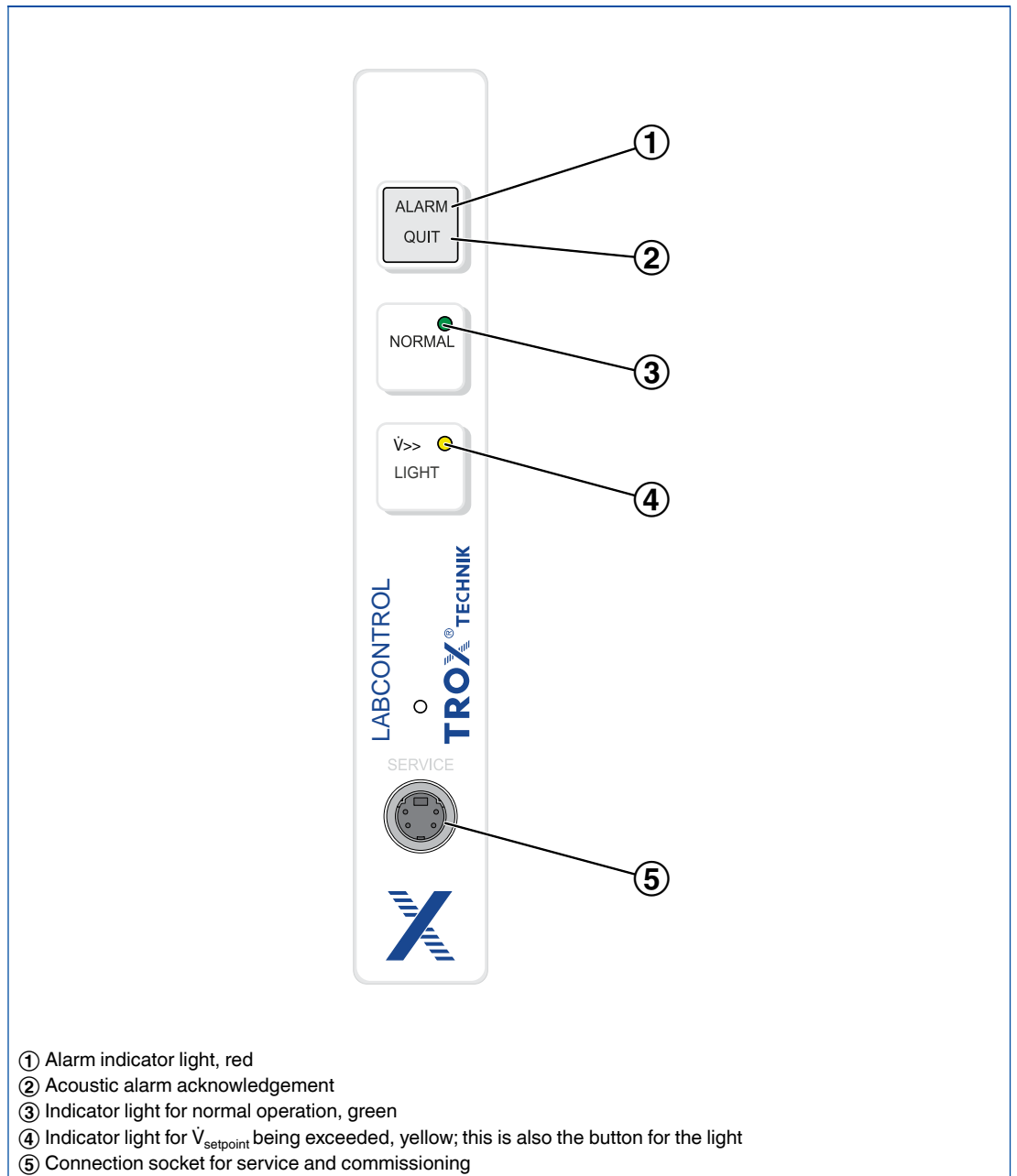

Description

Application

- Monitoring of the differential pressure in rooms or ducting
- Electric actual value signal, for example from a room pressure transducer (to be provided by others) or balance ring manometers

In many laboratory buildings or production facilities with critical safety requirements the room pressure is controlled. As the correct pressure cannot be felt, however, it should be made visible for the room occupants. The TPM is used to monitor and ensure the correct room pressure

2

Function

Functional description

The differential pressure is measured using a differential pressure transducer.

During commissioning with the MConnect configuration software the characteristic for the transducer is saved.

The monitoring system considers a minimum value and a maximum value (switching, e.g. from daytime to night-time operation). Separate alarms can be configured in case the actual value exceeds the setpoint or falls short of the setpoint.

- Alarm delay
- Duration of the alarm sounding; sound can also be suppressed

Alarm signalling to the central BMS can be achieved by wiring the alarm relay. The operating state is displayed on the control panel; optical and acoustic alarms are also emitted on the control panel. Room occupants can acknowledge alarms on the control panel. Depending on the setup the fume cupboard lighting can be switched on/off from the control panel. The monitoring system can be switched off.

Differential pressure control

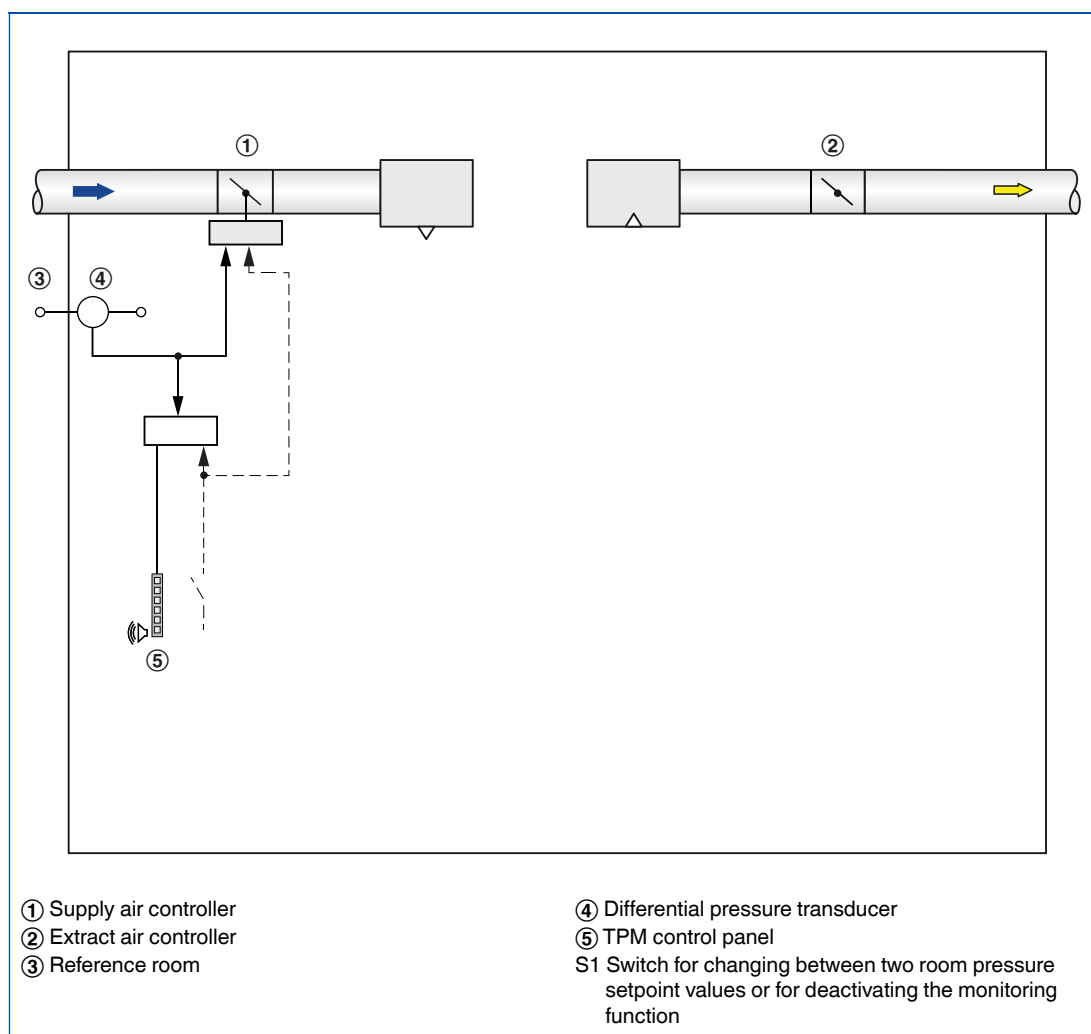

Monitoring of the room pressure

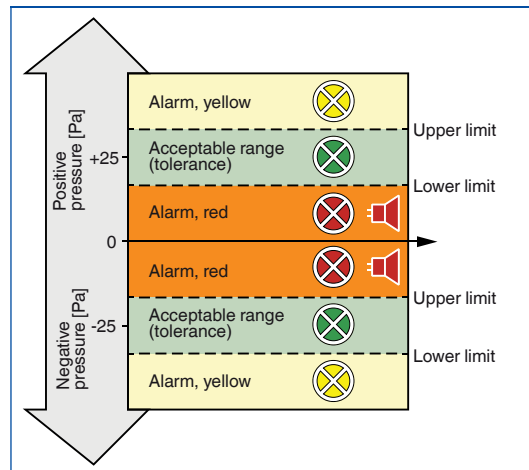

Function

TPM control panel

① Alarm indicator light, red
 ② Acoustic alarm acknowledgement
 ③ Indicator light for normal operation, green
 ④ Indicator light for differential pressure being too low, yellow; button for switching function
 ⑤ Connection socket for service and commissioning

Standard text

Monitoring devices for the monitoring of volume flow rate, room pressure, or face velocity on a fume cupboard. The quantity being monitored is received as a 0 – 10 V DC voltage signal from external transducers, e.g. face velocity transducer or volume flow measuring unit.

The monitoring system includes a microprocessor in a casing, a control panel (also for display), a sticker to mark the control panel for either volume flow rate and face velocity monitoring or for room pressure monitoring.

Special features

- Monitoring of volume flow rate, differential pressure or face velocity
- Measurement recording with transducer (to be provided by others) as 0 – 10 V signal
- Two values can be monitored, switching between the two is possible; alarms can be configured; monitoring can be switched off
- Optical and acoustic alarms are emitted on the control panel
- Signalling of normal operation, measured value higher or lower than setpoint, power failure
- Conventional alarm signalling (switch contact) to the central BMS
- On-site configuration with free-of-charge configuration software MConnect

Materials and surface

- Casing made of galvanised sheet steel, powder-coated, white
- Control panel made of plastic, light grey
- Control panel with front plastic (background HKS 91 30 %, buttons and text HKS 88 30 %)

Technical data

- Supply voltage: 24 V AC ± 15 %, 50/60 Hz
- Power rating: 3.5 VA
- Switch rating of relays: 250 V AC, 5 A

Air management control systems

Basic information and nomenclature

2



- Product selection

Air management control systems

Basic information and nomenclature

Product selection

	Control						Monitoring	
	System EASYLAB			System TCU-LON-II			TFM / TPM	
	Fume cupboard control	Room balancing	Room pressure control	Fume cupboard control	Room balancing	Room pressure control	TFM-1, TFM-2 Volume flow rate monitoring	TPM Room pressure monitoring
Area of application								
Hardware components								
Adapter module		●						
Expansion module for 230 V mains supply	Optional	Optional	Optional				Optional	
Expansion module for 230 V mains supply and UPS	Optional	Optional	Optional					
LonWorks interface	Optional	Optional	Optional	●	●	●		
Expansion module – solenoid valve	Optional	Optional	Optional	●	●	●		
Expansion module – fume cupboard lighting	Optional						●	
Control panel with 2-character display	●							
Control panel with 40-character display	●	●	●					
Control panel – TCU-LON-II standard				●			●	●
Control panel – expanded, AF-1							●	
Functions								
Monitoring – volume flow rate	●	●	●	●	●	●	●	
Monitoring – face velocity	●			●			Only with TFM-2	
Monitoring – sash position	●			●			●	
Monitoring – room pressure			●			●		●
Constant volume flow control	●	●		●	●			
Variable volume flow control	●	●		●	●			
Constant volume flow rate difference		●	●		●	●		
Room pressure control			●			●		
Room management function		●	●					
Additional functions								
Interface to central BMS	●	●	●	●	●	●	●	●
Damper blade position signal	●	●	●					
Diversity control		●	●		●	●		
Volume flow rate setpoint change		●	●		●	●		
Smoke extract	●							
Motion detector	●			●				
Control of automatic sash device	●						●	
Configuration software								
EasyConnect	●	●	●					
PlugIn TCU-LON II				●	●	●		
MConnect							●	●

● Possible □ Not possible