

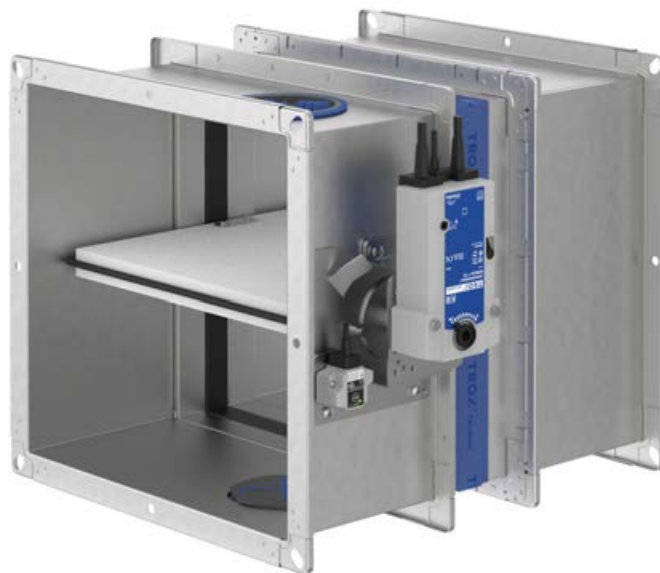

Fire damper

Type FK2-EU

according to Declaration of Performance
DoP / FK2-EU / DE / 002



Short version

This is a content-reduced short version. The full version is available at www.trox-docs.com.

TROX[®] TECHNIK

The art of handling air

TROX GmbH
Heinrich-Trox-Platz
47504 Neukirchen-Vluyn, Germany
Germany
Phone: +49 (0) 2845 2020
Fax: +49 (0) 2845 202-265
E-mail: trox-de@troxgroup.com
Internet: <http://www.troxtechnik.com>

Translation of the original
A00000092717, 1, GB/en
06/2022

© 2021

General information

About this manual

This operating and installation manual enables operating or service personnel to correctly install the TROX product described below and to use it safely and efficiently.

This operating and installation manual is intended for use by fitting and installation companies, in-house technicians, technical staff, instructed persons, and qualified electricians or air conditioning technicians.

It is essential that these individuals read and fully understand this manual before starting any work. The basic prerequisite for safe working is to comply with the safety notes and all instructions in this manual.

The local regulations for health and safety at work and general safety regulations also apply.

This manual must be given to the system owner when handing over the system. The system owner must include the manual with the system documentation. The manual must be kept in a place that is accessible at all times.

Illustrations in this manual are mainly for information and may differ from the actual design.

Copyright

This document, including all illustrations, is protected by copyright and pertains only to the corresponding product.

Any use without our consent may be an infringement of copyright, and the violator will be held liable for any damage.

This applies in particular to:

- Publishing content
- Copying content
- Translating content
- Microcopying content
- Saving content to electronic systems and editing it

TROX Technical Service

To ensure that your request is processed as quickly as possible, please keep the following information ready:

- Product name
- TROX order number
- Delivery date
- Brief description of the fault

| | |
|--------|--|
| Online | www.troxtechnik.com |
| Phone | +49 2845 202-400 |

Limitation of liability

The information in this manual has been compiled with reference to the applicable standards and guidelines, the state of the art, and our expertise and experience of many years.

The manufacturer does not accept any liability for damages resulting from:

- Non-compliance with this manual
- Incorrect use
- Operation or handling by untrained individuals
- Unauthorised modifications
- Technical changes
- Use of non-approved replacement parts

The actual scope of delivery may differ from the information in this manual for bespoke constructions, additional order options or as a result of recent technical changes.

The obligations agreed in the order, the general terms and conditions, the manufacturer's terms of delivery, and the legal regulations in effect at the time the contract is signed shall apply.

We reserve the right to make technical changes.

Warranty claims

The provisions of the respective general delivery terms apply to warranty claims. For purchase orders placed with TROX GmbH, these are the regulations in section "VI. Warranty claims" of the Delivery Terms of TROX GmbH, see www.trox.de/en/.

Safety notes

Symbols are used in this manual to alert readers to areas of potential hazard. Signal words express the degree of the hazard.

Comply with all safety instructions and proceed carefully to avoid accidents, injuries and damage to property.

DANGER!

Imminently hazardous situation which, if not avoided, will result in death or serious injury.

WARNING!

Potentially hazardous situation which, if not avoided, may result in death or serious injury.

CAUTION!

Potentially hazardous situation which, if not avoided, may result in minor or moderate injury.

NOTICE!

Potentially hazardous situation which, if not avoided, may result in property damage.

ENVIRONMENT!

Environmental pollution hazard.

Tips and recommendations



Useful tips and recommendations as well as information for efficient and fault-free operation.

Safety notes as part of instructions

Safety notes may refer to individual instructions. In this case, safety notes will be included in the instructions and hence facilitate following the instructions. The above listed signal words will be used.

Example:

1. ▶ Loosen the screw.

2. ▶

CAUTION!

Danger of finger entrapment when closing the lid.

Be careful when closing the lid.

3. ▶ Tighten the screw.

Specific safety notes

The following symbols are used in safety notes to alert you to specific hazards:

| Warning signs | Type of danger |
|---|------------------------|
|  | Warning – danger zone. |

| | | | | |
|----------|---|-----------|-----------|----------------------------|
| 1 | Safety | 6 | | |
| 1.1 | General safety notes | 6 | | |
| 1.2 | Correct use | 6 | 7 | Commissioning |
| 1.3 | Qualified staff | 7 | 8 | Index |
| 2 | Technical data | 8 | | |
| 2.1 | General data | 8 | | |
| 2.2 | FK2-EU with fusible link | 10 | | |
| 2.3 | FK2-EU with spring return actuator | 13 | | |
| 2.4 | FK2-EU with spring return actuator and duct smoke detector | 20 | | |
| 2.5 | FK2-EU with fusible link and cover grille as air transfer unit | 21 | | |
| 2.6 | FK2-EU with spring return actuator and duct smoke detector as air transfer damper | 22 | | |
| 3 | Supply package, transport and storage | 24 | | |
| 4 | Installation | 25 | | |
| 4.1 | Installation situations | 25 | | |
| 4.2 | Safety notes regarding installation | 30 | | |
| 4.3 | General installation information | 30 | | |
| 4.4 | Solid walls | 43 | | |
| 4.4.1 | General | 43 | | |
| 4.4.2 | Mortar-based installation | 44 | | |
| 4.5 | Lightweight partition walls | 46 | | |
| 4.5.1 | General | 46 | | |
| 4.5.2 | Dry mortarless installation with installation kit ES | 52 | | |
| 4.5.3 | Dry mortarless installation with fire batt | 55 | | |
| 4.6 | Fixing the fire damper | 59 | | |
| 4.6.1 | General | 59 | | |
| 4.6.2 | Suspending fire dampers installed remote from solid walls and ceiling slabs | 60 | | |
| 4.6.3 | Fixing the damper when a fire batt is used | 61 | | |
| 5 | Electrical connection | 64 | | |
| 5.1 | General safety notes | 64 | | |
| 5.2 | Limit switches (fire dampers with fusible link) | 64 | | |
| 5.3 | Spring return actuator | 64 | | |
| 5.4 | Spring return actuator and duct smoke detector RM-O-3-D | 64 | | |
| 6 | Functional test | 65 | | |
| 6.1 | General | 65 | | |
| 6.2 | Functional test with automatic control unit | 65 | | |
| 6.3 | Fire damper with fusible link | 66 | | |
| 6.3.1 | Fusible link – size 1 | 66 | | |
| 6.3.2 | Fusible link – sizes 2 and 3 | 67 | | |
| 6.4 | Fire damper with spring return actuator .. | 70 | | |
| | 6.4.1 Spring return actuator – BFL... / BFN... | | | 70 |
| | 7 | | 72 | |
| | 8 | | 73 | |

1 Safety

1.1 General safety notes

Sharp edges, sharp corners and thin sheet metal parts

 **CAUTION!**

Danger of injury from sharp edges, sharp corners and thin sheet metal parts!

Sharp edges, sharp corners and thin sheet metal parts may cause cuts or grazes.

- Be careful when carrying out any work.
- Wear protective gloves, safety shoes and a hard hat.

Electrical voltage

 **DANGER!**

Danger of electric shock! Do not touch any live components! Electrical equipment carries a dangerous electrical voltage.

- Only skilled qualified electricians are allowed to work on the electrical system.
- Switch off the power supply before working on any electrical equipment.

1.2 Correct use

- The fire damper is used as an automatic shut-off device to prevent fire and smoke from spreading through ducting.
- The fire damper is suitable for supply and extract air in HVAC systems.
- The fire damper may be used in potentially explosive atmospheres if appropriate special accessories are used with it and if the product bears the CE conformity marking according to Directive 94/9/EC. Fire dampers for use in potentially explosive atmospheres are marked for the zones for which they have been approved.
- Operation of the fire dampers is allowed only in compliance with installation regulations and the technical data in this installation and operating manual.
- Modifying the fire damper or using replacement parts that have not been approved by TROX is not permitted.

If this fire damper is used in Germany:

- Do not use it in extract air systems in commercial kitchens.
- Not to be used as an air transfer damper.
- Do not use in combined penetration seal.
- Do not use in fire protection block bulkhead.
- Approvals under building regulations may be required for the use of upstream shutters for air transfer units. This must be checked and applied for by others.
- Flame-resistant, non-dripping building materials (elastomeric foams) must at least correspond to fire rating class C - s2, d0 according to the specifications of MVV TB (since 2019/1). The applicable local building regulations must be observed.

Incorrect use

 **WARNING!**

Danger due to incorrect use!

Incorrect use of the fire damper can lead to dangerous situations.

Never use the fire damper

- without specially approved attachments in areas with potentially explosive atmospheres
- as a smoke control damper
- outdoors without sufficient protection against the effects of weather
- in atmospheres where chemical reactions, whether planned or unplanned, may cause damage to the fire damper or lead to corrosion

1.3 Qualified staff

**WARNING!****Danger of injury due to insufficiently qualified individuals!**

Incorrect use may cause considerable injury or damage to property.

- Only specialist personnel must carry out work.

Personnel:

- Skilled qualified electrician
- Specialist personnel

Skilled qualified electrician

Skilled qualified electricians are individuals who have sufficient professional or technical training, knowledge and actual experience to enable them to work on electrical systems, understand any potential hazards related to the work under consideration, and recognise and avoid any risks involved.

Specialist personnel

Specialist personnel are individuals who have sufficient professional or technical training, knowledge and actual experience to enable them to carry out their assigned duties, understand any potential hazards related to the work under consideration, and recognise and avoid any risks involved.

2 Technical data

2.1 General data

| | |
|---|---|
| Nominal sizes B × H | 200 × 100 – 1500 × 800 mm * |
| Casing lengths L | 305 and 500 mm |
| Volume flow rate range | Up to 14400 l/s or 51840 m³/h |
| Differential pressure range | Up to 2000 Pa |
| Temperature range ^{1, 3, 4} | -20 °C to 50 °C |
| Release temperature ⁴ | 72 °C or 95 °C (for warm air ventilation systems) |
| Upstream velocity ^{2, 4} | ≤ 8 m/s with fusible link, ≤ 12 m/s with spring return actuator ≤ 10 m/s with explosion-proof spring return actuator |
| Closed blade air leakage | EN 1751, Class 2 |
| Casing leakage | EN 1751, L = 305 mm, class C L = 500 mm, class C; (B + H) ≤ 700, class B |
| EC conformity | <ul style="list-style-type: none"> ■ Construction Products Regulation (EU) no. 305/2011 ■ EN 15650 – Ventilation for buildings – Fire dampers ■ EN 13501-3 – Classification: Fire resistant ducts and fire dampers ⁵ ■ EN 1366-2 – Fire resistance tests for installations: Fire dampers ■ EN 1751 Ventilation for buildings – Air terminal devices |
| Declaration of performance | DoP / FK2-EU / DE / 002 |

¹⁾ Temperatures may differ for units with attachments. Details for other applications are available on request.

²⁾ Data applies to uniform upstream and downstream conditions for the fire damper.

³⁾ Condensation and the intake of humid fresh air have to be avoided as otherwise operation will be impaired or not possible.

⁴⁾ For explosion-proof FK2-EU construction see the supplementary operating manual.

⁵⁾ Leakage rate of the fire damper system tested at 300 Pa and 500 Pa negative pressure.

* Damper blade with lip seal for sizes 1 and 2, damper blade with travel stop seal for size 3, see table 11.

Product sticker

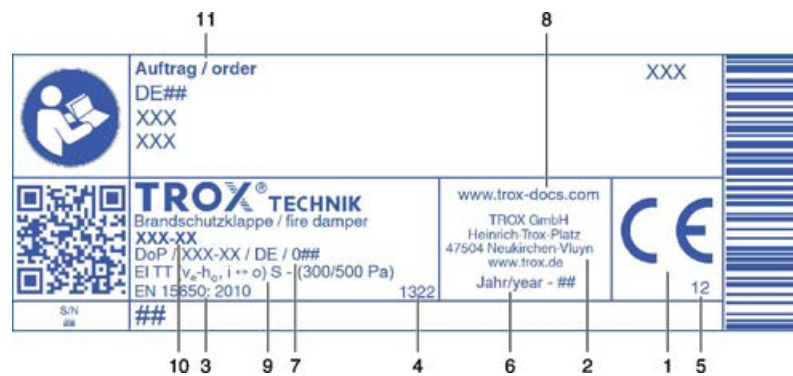

Fig. 1: Product sticker (example)

- | | | | |
|---|---|----|---|
| 1 | CE mark | 7 | No. of the declaration of performance |
| 2 | Manufacturer's address | 8 | Website from which the DoP can be downloaded |
| 3 | Number of the European standard and year of its publication | 9 | Regulated characteristics; the fire resistance class depends on the application and may vary ↳ <i>Chapter 4.1 'Installation situations' on page 25</i> |
| 4 | Notified body | 10 | Type |
| 5 | The last two digits of the year in which the CE marking was affixed | 11 | Order number |
| 6 | Year of manufacture | | |

2.2 FK2-EU with fusible link

Dimensions and weight

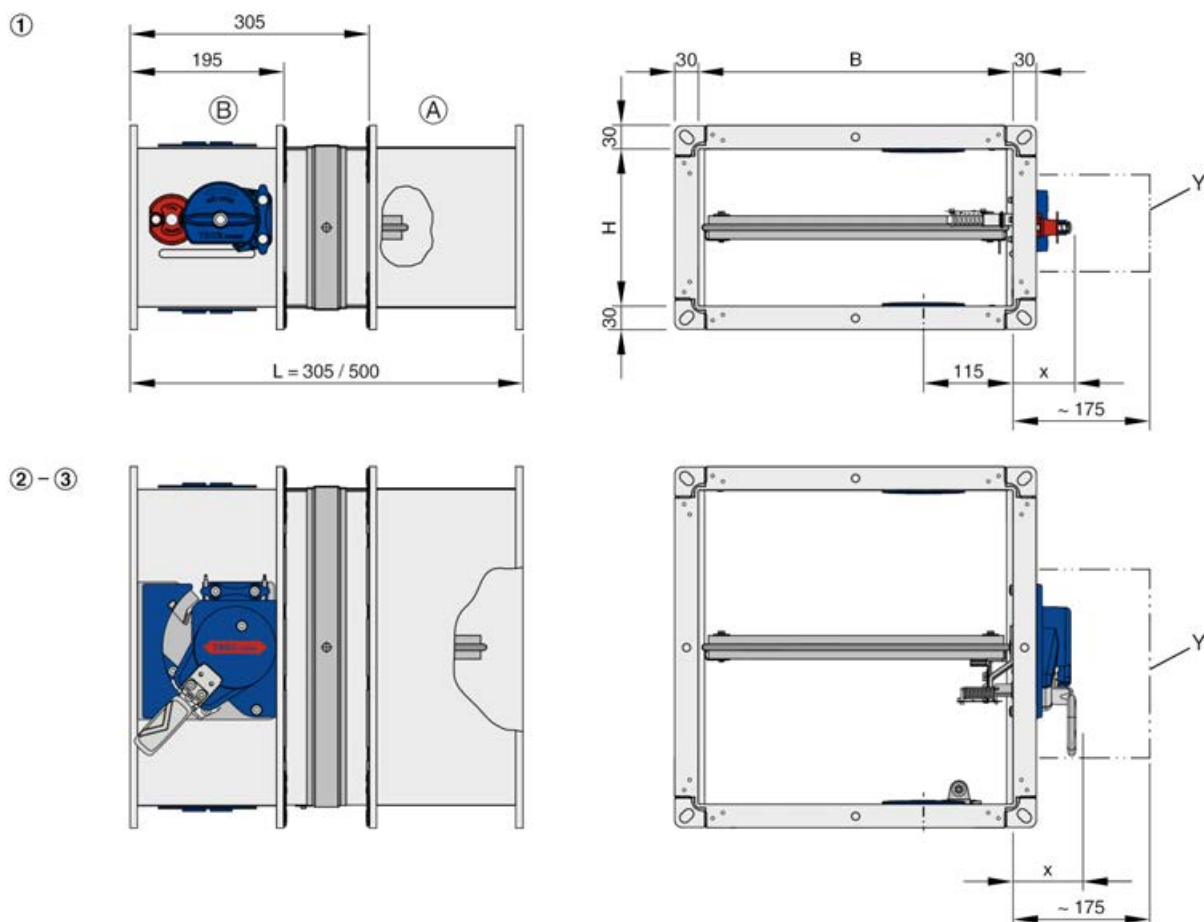

Fig. 2: FK2-EU with fusible link

- | | | | |
|----|--|-----|---------------------|
| B | Width of the fire damper (side B) | x | 75 mm size 1 |
| H | Height of the fire damper (side H) | | 87 mm sizes 2 and 3 |
| FL | Length of the fire damper (casing length) | (A) | Installation side |
| Y | Keep clear to provide access for operation | (B) | Operating side |

- Weight of FK2-EU with fusible link, see table 11.
- Sizes 1 to 3, see table 11.
- Flange dimensions for L = 305 mm, see Fig. 3.

Limit switch

| | |
|--|-----------------------------------|
| Connecting cable length / cross section | 1 m / 3 × 0.34 mm ² |
| Protection level | IP 66 |
| Type of contact | 1 changeover contact, gold-plated |
| Maximum switching current | 0.5 A |
| Maximum switching voltage | 30 V DC, 250 V AC |
| Contact resistance | approx. 30 mΩ |

Weight [kg] for casing length L = 305 [mm] / L = 500 [mm]

| H [mm] | B [mm] | | | | | | | | | | | | | | 1 | |
|-----------|--------|-------|-------|-------|-------|-------|-------|-------|-------|-------|-------|-------|-------|-------|-----|-----|
| | 200 | 300 | 400 | 500 | 600 | 700 | 800 | 900 | 1000 | 1100 | 1200 | 1300 | 1400 | 1500 | | |
| 100 | 4/5 | 5/6 | 6/8 | 7/9 | 8/11 | 9/12 | 10/13 | - | - | - | - | - | - | - | - | [A] |
| 150 | 4/6 | 5/7 | 7/9 | 8/10 | 9/12 | 10/13 | 11/15 | - | - | - | - | - | - | - | | |
| 200 | 5/7 | 6/8 | 7/10 | 9/12 | 10/13 | 11/15 | 12/16 | 15/20 | 16/21 | 21/27 | 23/29 | 24/31 | 26/32 | 27/34 | | |
| 250 | 7/9 | 8/10 | 10/12 | 11/14 | 12/16 | 14/18 | 15/19 | 16/21 | 18/23 | 24/29 | 25/31 | 27/33 | 29/35 | 30/38 | | |
| 300 | 8/10 | 9/12 | 11/14 | 12/15 | 13/17 | 15/19 | 16/21 | 18/23 | 19/25 | 26/32 | 28/34 | 30/36 | 32/39 | 33/41 | | |
| 350 | 8/11 | 10/13 | 11/15 | 13/17 | 15/18 | 16/20 | 18/22 | 24/29 | 26/32 | 28/34 | 30/37 | 32/39 | 34/42 | 36/44 | | |
| 400 | 9/11 | 11/13 | 12/16 | 14/18 | 16/20 | 17/22 | 19/24 | 26/31 | 28/34 | 31/37 | 33/39 | 35/42 | 37/45 | 39/47 | | |
| 450 | 10/12 | 11/14 | 13/17 | 15/19 | 17/21 | 23/28 | 26/31 | 28/34 | 30/36 | 33/39 | 35/42 | 38/45 | 40/48 | 43/50 | [B] | |
| 500 | 10/13 | 12/15 | 14/18 | 16/20 | 18/22 | 25/30 | 27/33 | 30/36 | 33/39 | 35/42 | 36/45 | 40/48 | 43/51 | 46/54 | | |
| 550 | - | 15/19 | 18/22 | 21/26 | 24/28 | 26/32 | 29/35 | 32/38 | 35/41 | 37/44 | 40/47 | 43/51 | 46/54 | 49/57 | | |
| 600 | - | 16/20 | 19/23 | 22/27 | 25/30 | 28/33 | 31/37 | 34/40 | 37/43 | 40/47 | 43/50 | 46/53 | 49/57 | 52/60 | | |
| 650 | - | 17/21 | 20/25 | 23/28 | 27/32 | 30/35 | 33/39 | 36/42 | 39/46 | 42/49 | 45/53 | 48/56 | 51/60 | 55/63 | | |
| 700 | - | 18/22 | 21/26 | 25/30 | 28/33 | 31/37 | 35/41 | 38/44 | 41/48 | 44/52 | 48/55 | 51/59 | 54/63 | 58/67 | | |
| 750 | - | 19/23 | 22/27 | 26/31 | 29/35 | 33/39 | 36/43 | 40/47 | 43/50 | 47/54 | 50/58 | 54/62 | 57/66 | 61/70 | | |
| 800 | - | 20/24 | 24/28 | 27/33 | 31/36 | 34/40 | 38/44 | 42/49 | 45/53 | 49/57 | 53/61 | 56/65 | 60/69 | 64/73 | | |

1) Construction with spring return actuator: [A] = Horizontally arranged spring return actuator, [B] = Vertically arranged spring return actuator

Sizes



Damper blade (30 mm thick) with lip seal for sizes 1 and 2, damper blade (40 mm thick) with travel stop seal for size 3.

Flange holes

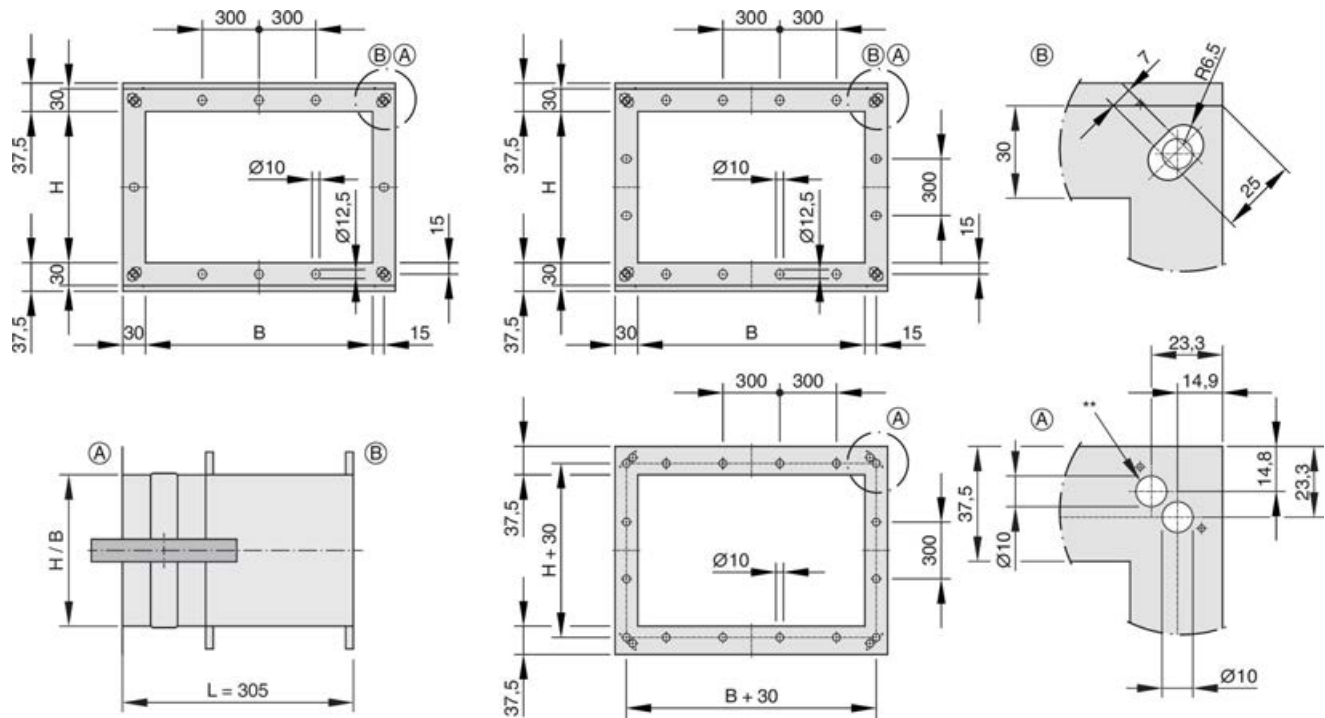

Fig. 3: Flange holes $L = 305$ mm – uneven and even number of holes

** Other flange holes (non-standard)

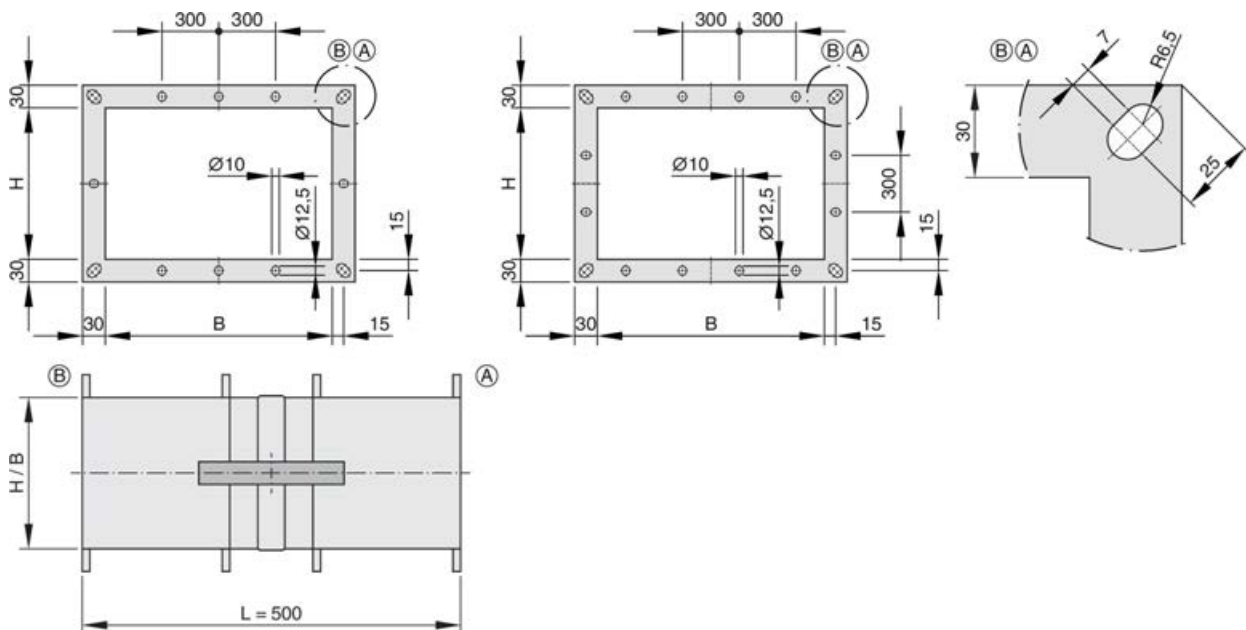

Fig. 4: Flange holes $L = 500$ mm – uneven and even number of holes

| B or H [mm] | 200/100 – 355 | 360 – 630 | 635 – 800 | 805 – 1250 | 1255 – 1500 |
|--|---------------|-----------|-----------|------------|-------------|
| No. of holes on each side excluding corner holes | – | 1 | 2 | 3 | 4 |

2.3 FK2-EU with spring return actuator

Dimensions and weight

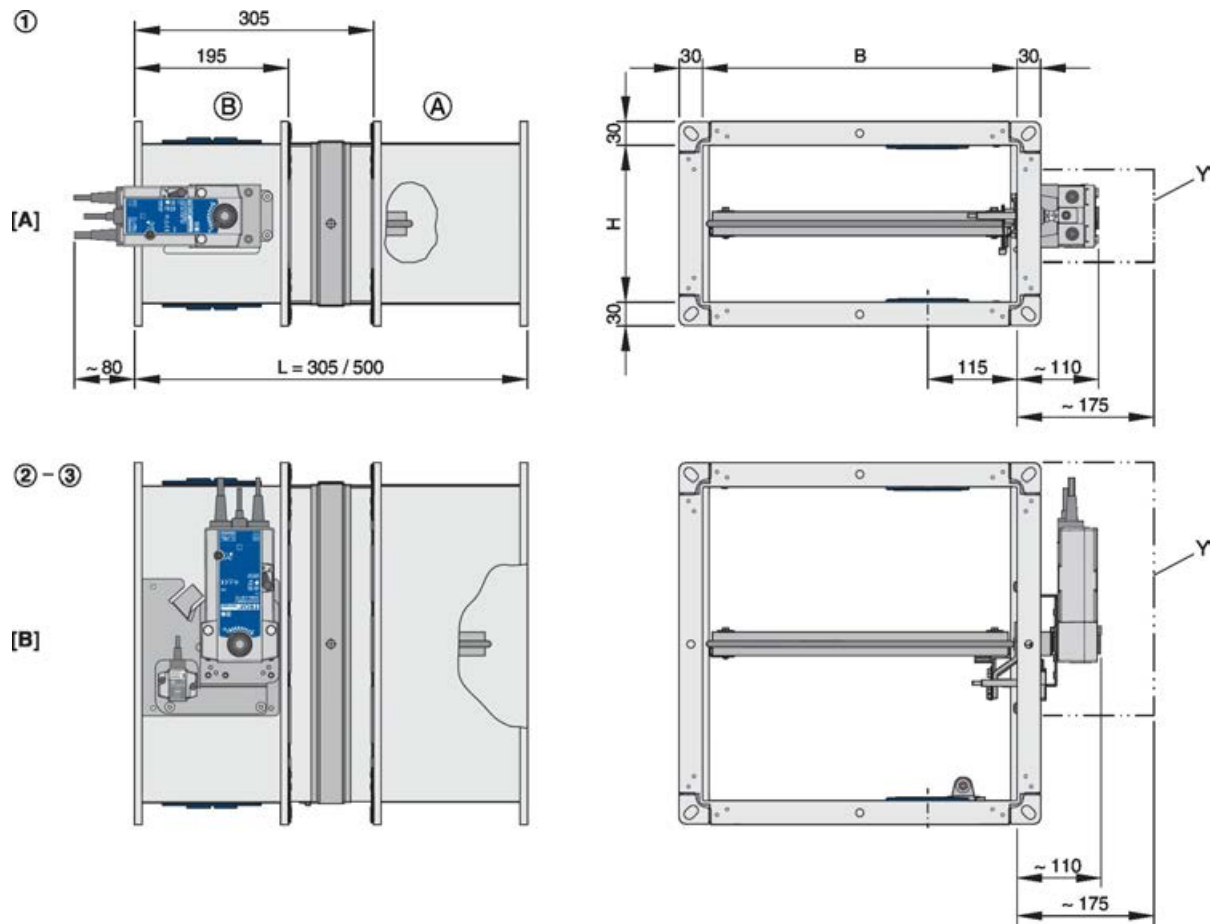

Fig. 5: FK2-EU with Belimo spring return actuator

- | | | | |
|-----|---|-----|--|
| B | Width of the fire damper (side B) | [B] | Spring return actuator vertical |
| H | Height of the fire damper (side H) | Y | Keep clear to provide access for operation |
| FL | Length of the fire damper (casing length) | (A) | Installation side |
| [A] | Spring return actuator horizontal | (B) | Operating side |

- Weight of FK2-EU with fusible link + approx. 1 kg (BFL... and BFN...), see table ↗ 11 .
- For sizes 1 to 3 and orientation of the spring return actuator [A] or [B] see table ↗ 11 .
- Flange dimensions for L = 305 mm, see Fig. 3 .

| Spring return actuator BFL... | | | |
|---|--|--|--------------------------------------|
| Construction | | 230-T TR | 24-T-ST TR |
| Supply voltage | | 230 V AC, 50/60 Hz | 24 V AC/DC, 50/60 Hz |
| Functional range | | 198 – 264 V AC | 19.2 – 28.8 V AC 21.6 – 28.8 V DC |
| Power rating | Spring winding mechanism / hold position | 3.5 W / 1.1 W | 2.5 W / 0.8 W |
| | Rating | 6.5 VA | 4 VA |
| Running time | Actuator / spring return | < 60 s / < 20 s | |
| Limit switch | Type of contact | 2 changeover contacts | |
| | Switching voltage | 5 – 120 V DC / 5 – 250 V AC | |
| | Switching current | 1 mA – 3 (0.5 inductive) A | |
| | Contact resistance | < 1 Ω (when new) | |
| IEC protection class / IP protection | | II / IP 54 | |
| Storage temperature / ambient temperature | | -40 – 55 °C / -30 – 55 °C ¹ | |
| Ambient humidity | | ≤ 95% rh, no condensation | |
| Connecting cable | Actuator / limit switch | 1 m, 2 × 0.75 mm ² / 1 m, 6 × 0.75 mm ² (free of halogens) | |

Spring return actuator type BFL... for size 1.

¹ Up to 75 °C the safe position will definitely be reached.

| Spring return actuator BFN... | | | |
|--|--|--|--------------------------------------|
| Construction | | 230-T TR | 24-T-ST TR |
| Supply voltage | | 230 V AC, 50/60 Hz | 24 V AC/DC, 50/60 Hz |
| Functional range | | 198 – 264 V AC | 19.2 – 28.8 V AC 21.6 – 28.8 V DC |
| Power rating | Spring winding mechanism / hold position | 5 W / 2.1 W | 4 W / 1.4 W |
| | Rating | 10 VA (I _{max} 4 A @ 5 ms) | 6 VA (I _{max} 8.3 A @ 5 ms) |
| Running time | Actuator / spring return | < 60 s / < 20 s | |
| Limit switch | Type of contact | 2 changeover contacts | |
| | Switching voltage | 5 – 120 V DC / 5 – 250 V AC | |
| | Switching current | 1 mA – 3 (0.5 inductive) A | |
| | Contact resistance | < 1 Ω (when new) | |
| IEC protection class / IP protection | | II / IP 54 | |
| Storage temperature / ambient temperature | | -40 – 55 °C / -30 – 55 °C ¹ | |
| Ambient humidity | | ≤ 95% rh, no condensation | |
| Connecting cable | Actuator / limit switch | 1 m, 2 × 0.75 mm ² / 1 m, 6 × 0.75 mm ² (free of halogens) | |

Spring return actuator type BFN... for size 2 and 3.

¹ Up to 75 °C the safe position will definitely be reached.

FK2-EU with spring return actuator

| Spring return actuator BF... | | | |
|--|--|--|--------------------------------------|
| Construction | | 230-TN TR | 24-TN-ST TR |
| Supply voltage | | 230 V AC, 50/60 Hz | 24 V AC/DC, 50/60 Hz |
| Functional range | | 198 – 264 V AC | 19.2 – 28.8 V AC 21.6 – 28.8 V DC |
| Power rating | Spring-winding mechanism / hold position | 8.5 W / 3 W | 7 W / 2 W |
| | Rating | 11 VA | 10 VA |
| Run time | Actuator / spring return | < 120 s / approx. 16 s | |
| Limit switch | Type of contact | 2 changeover contact | |
| | Switching voltage | 5 – 120 V DC / 5 – 250 V AC | |
| | Switching current | 1 mA ... 6 A | |
| | Contact resistance | < 100 mΩ | |
| IEC protection class / IP protection | | II / IP 54 | III / IP 54 |
| Storage temperature / ambient temperature | | -40 to 50 °C / -30 to 50 °C ¹ | |
| Ambient humidity | | ≤ 95% rh, no condensation | |
| Connecting cable | Actuator / limit switch | 1 m, 2 × 0.75 mm ² / 1 m, 6 × 0.75 mm ² (free of halogens) | |

BF actuator optional / upon request, weight of FK2-EU with fusible link + approx. 2 kg

¹ Up to 75 °C the safe position will definitely be reached.

Dimensions and weight

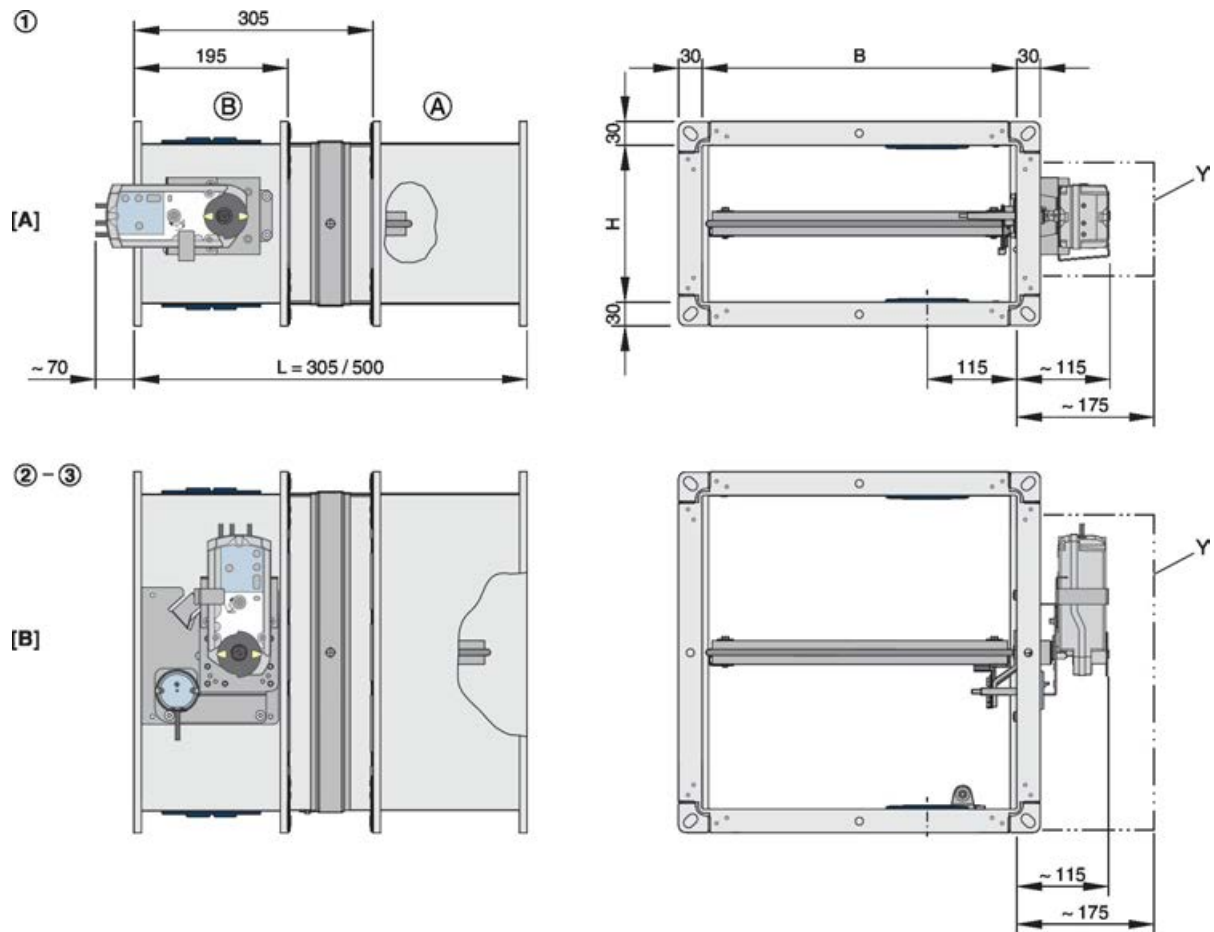

Fig. 6: FK2-EU with Siemens spring return actuator

- | | | | |
|-----|---|-----|--|
| B | Width of the fire damper (side B) | [B] | Spring return actuator vertical |
| H | Height of the fire damper (side H) | Y | Keep clear to provide access for operation |
| FL | Length of the fire damper (casing length) | (A) | Installation side |
| [A] | Spring return actuator horizontal | (B) | Operating side |

- Weight of FK2-EU with fusible link + approx. 1.4 kg (GRA... and GNA...), see table 11.
- For sizes 1 to 3 and orientation of the spring return actuator [A] or [B] see table 11.
- Flange dimensions for L = 305 mm, see Fig. 3.

| Spring return actuator GRA... | | | |
|---|--------------------------|--|--------------------------------------|
| Construction | | 326.1E | 126.1E |
| Supply voltage | | 230 V AC, 50/60 Hz | 24 V AC, 50/60 Hz / 24 – 48 V DC |
| Functional range | | 198 – 264 V AC | 19.2 – 28.8 V AC 19.2 – 57.6 V DC |
| Power rating | Spring winding mechanism | 7 VA / 4.5 W | 5 VA / 3.5 W |
| | Hold position | 3.5 W | 2 W |
| Running time | Actuator / spring return | 90 s / 15 s | |
| Limit switch | Type of contact | 2 changeover contacts | |
| | Switching voltage | 24 – 230 V AC / 12 – 30 V DC | |
| | Switching current | AC: 6 A (inductive 2 A) / DC: 2 A | |
| IEC protection class / IP protection | | II / IP 42 or IP 54* | III / IP 42 or IP 54* |
| Storage temperature / ambient temperature | | -20 to 50 °C / -20 to 50 °C | |
| Ambient humidity | | < 95% rh, no condensation | |
| Connecting cable | Actuator / limit switch | 0.9 m, 6 × 0.75 mm ² (free of halogens) | |

Spring return actuator type GRA... for size 1.

*Connecting cable at the bottom

| Spring return actuator GNA... | | | |
|---|--------------------------|--|--------------------------------------|
| Construction | | 326.1E | 126.1E |
| Supply voltage | | 230 V AC, 50/60 Hz | 24 V AC, 50/60 Hz / 24 – 48 V DC |
| Functional range | | 198 – 264 V AC | 19.2 – 28.8 V AC 19.2 – 57.6 V DC |
| Power rating | Spring winding mechanism | 7 VA / 4.5 W | 5 VA / 3.5 W |
| | Hold position | 3.5 W | 2 W |
| Running time | Actuator / spring return | 90 s / 15 s | |
| Limit switch | Type of contact | 2 changeover contacts | |
| | Switching voltage | 24 – 230 V AC / 12 – 30 V DC | |
| | Switching current | AC: 6 A (inductive 2 A) / DC: 2 A | |
| IEC protection class / IP protection | | II / IP 42 or IP 54* | III / IP 42 or IP 54* |
| Storage temperature / ambient temperature | | -20 to 50 °C / -20 to 50 °C | |
| Ambient humidity | | < 95% rh, no condensation | |
| Connecting cable | Actuator / limit switch | 0.9 m, 6 × 0.75 mm ² (free of halogens) | |

Spring return actuator type GNA... for sizes 2 and 3.

*Connecting cable at the bottom

| Spring return actuator GGA... | | | |
|---|--------------------------|--|--------------------------------------|
| Construction | | 326.1E | 126.1E |
| Supply voltage | | 230 V AC, 50/60 Hz | 24 V AC, 50/60 Hz / 24 – 48 V DC |
| Functional range | | 198 – 264 V AC | 19.2 – 28.8 V AC 19.2 – 57.6 V DC |
| Power rating | Spring-winding mechanism | 8 VA / 6 W | 7 VA / 5 W |
| | Hold position | 4 W | 3 W |
| Run time | Actuator / spring return | 90 s / 15 s | |
| Limit switch | Type of contact | 2 changeover contact | |
| | Switching voltage | 24 – 230 V AC / 12 – 30 V DC | |
| | Switching current | AC: 6 A (inductive 2 A) / DC: 2 A | |
| IEC protection class / IP protection | | II / IP 42 or IP 54* | III / IP 42 or IP 54* |
| Storage temperature / ambient temperature | | -20 to 50 °C / -20 to 50 °C | |
| Ambient humidity | | < 95% rh, no condensation | |
| Connecting cable | Actuator / limit switch | 0.9 m, 6 × 0.75 mm ² (free of halogens) | |

GGA actuator optional / upon request, weight of FK2-EU with fusible link + approx. 2.5 kg

*Connecting cable at the bottom

FK2-EU with Joventa spring return actuator

FK2-EU can also be supplied with a Joventa spring return actuator (upon request):

- SFR 2.90 T
- SFR 1.90 T
- SFR 1.90 T SLC

FK2-EU with explosion-proof Schischek spring return actuator

FK2-EU can also be supplied with an explosion-proof Schischek spring return actuator (upon request):

- ExMax-15-BF-TR
- RedMax-15-BF-TR

For more information see the Supplementary operating manual for explosion-proof fire dampers type FK2-EU.

2.4 FK2-EU with spring return actuator and duct smoke detector

Dimensions and weight

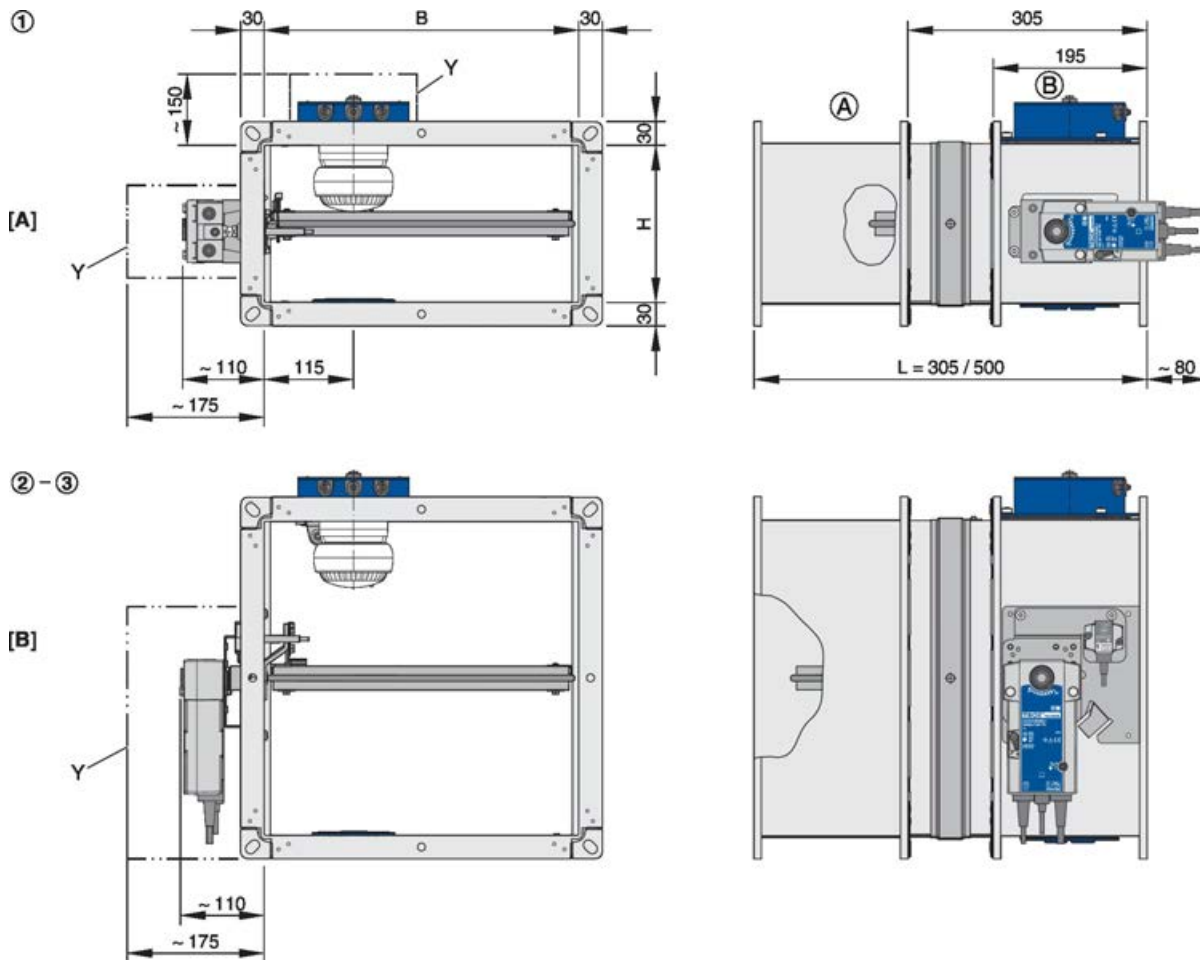

Fig. 7: FK2-EU with Belimo spring return actuator and duct smoke detector

| | | | |
|-----|---|-----|--|
| B | Width of the fire damper (side B) | [B] | Spring return actuator vertical |
| H | Height of the fire damper (side H) | Y | Keep clear to provide access for operation |
| FL | Length of the fire damper (casing length) | (A) | Installation side |
| [A] | Spring return actuator horizontal | (B) | Operating side |

- Weight of FK2-EU with fusible link + approx. 2.5 kg (BFL... and BFN...), see table 11.
- For technical data of the spring return actuator see table 14 and 16
- For sizes 1 to 3 and orientation of the spring return actuator [A] or [B] see table 11.
- Install the duct smoke detector RM-O-3-D in the lower inspection access, and at the top when you install the fire damper. For technical details of the duct smoke detector see the RM-O-3-D operating and installation manual.

2.5 FK2-EU with fusible link and cover grille as air transfer unit

Dimensions and weight

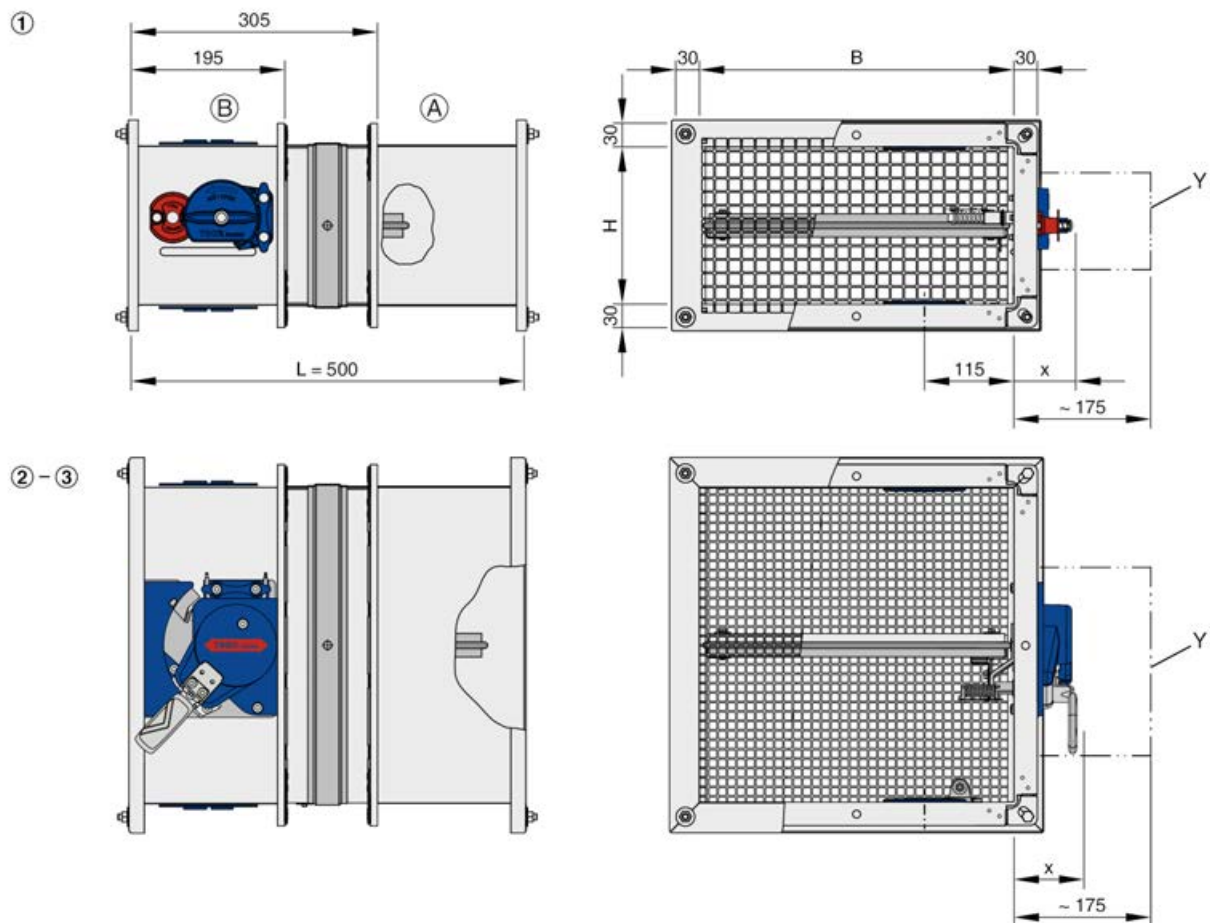

Fig. 8: FK2-EU with fusible link and cover grille as air transfer unit

| | | | |
|----|--|-----|---------------------|
| B | Width of the fire damper (side B) | x | 75 mm size 1 |
| H | Height of the fire damper (side H) | | 87 mm sizes 2 and 3 |
| FL | Length of the fire damper (casing length) | (A) | Installation side |
| Y | Keep clear to provide access for operation | (B) | Operating side |

- Sizes 1 to 3, see table 11.

Note: Air transfer units may require a building inspectorate licence. This has to be determined and applied for on a case to case basis (by others).

FK2-EU with spring return actuator and duct smoke...

2.6 FK2-EU with spring return actuator and duct smoke detector as air transfer damper

Dimensions and weight

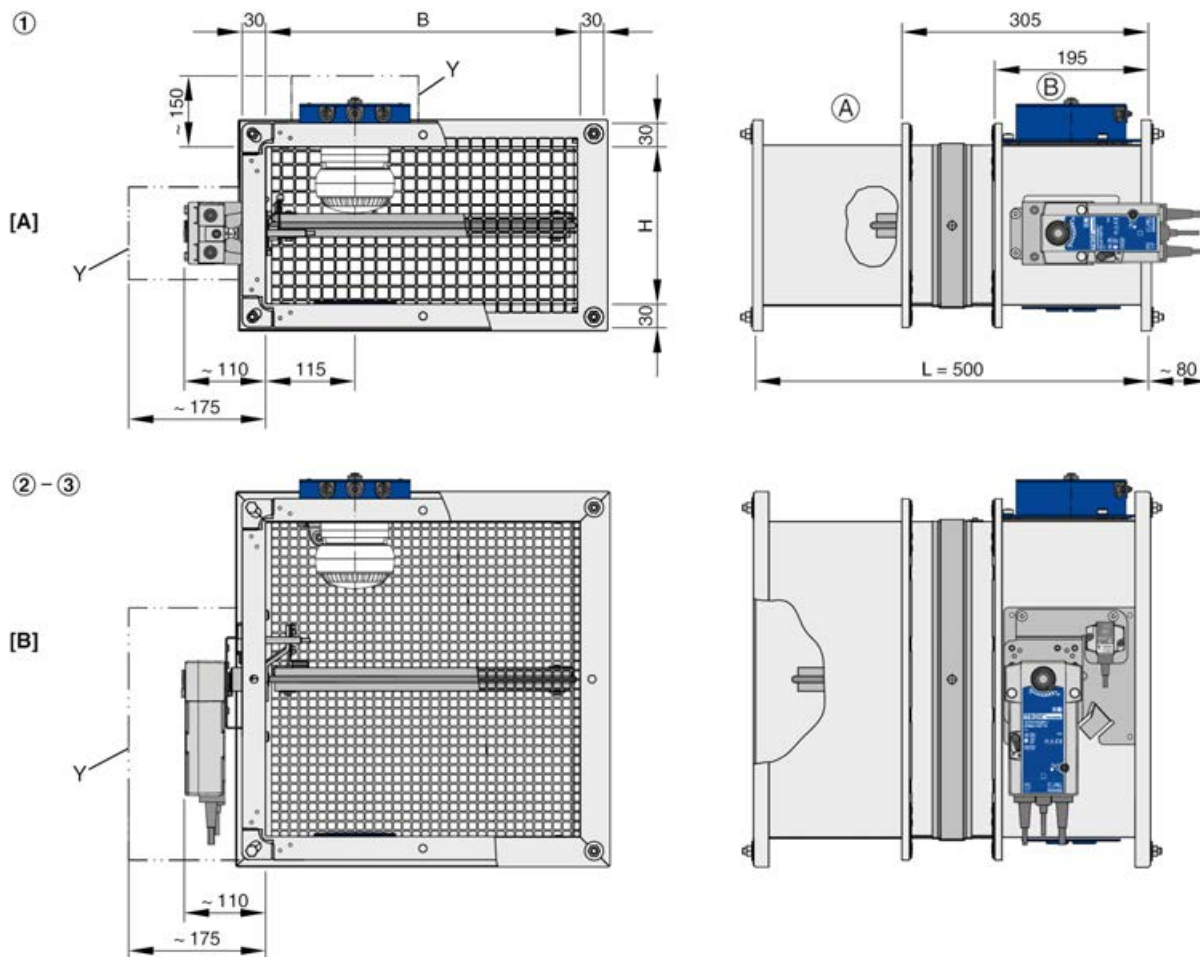

Fig. 9: FK2-EU with spring return actuator and duct smoke detector as air transfer damper

- | | | | |
|-----|---|-----|--|
| B | Width of the fire damper (side B) | [B] | Spring return actuator vertical |
| H | Height of the fire damper (side H) | Y | Keep clear to provide access for operation |
| FL | Length of the fire damper (casing length) | (A) | Installation side |
| [A] | Spring return actuator horizontal | (B) | Operating side |

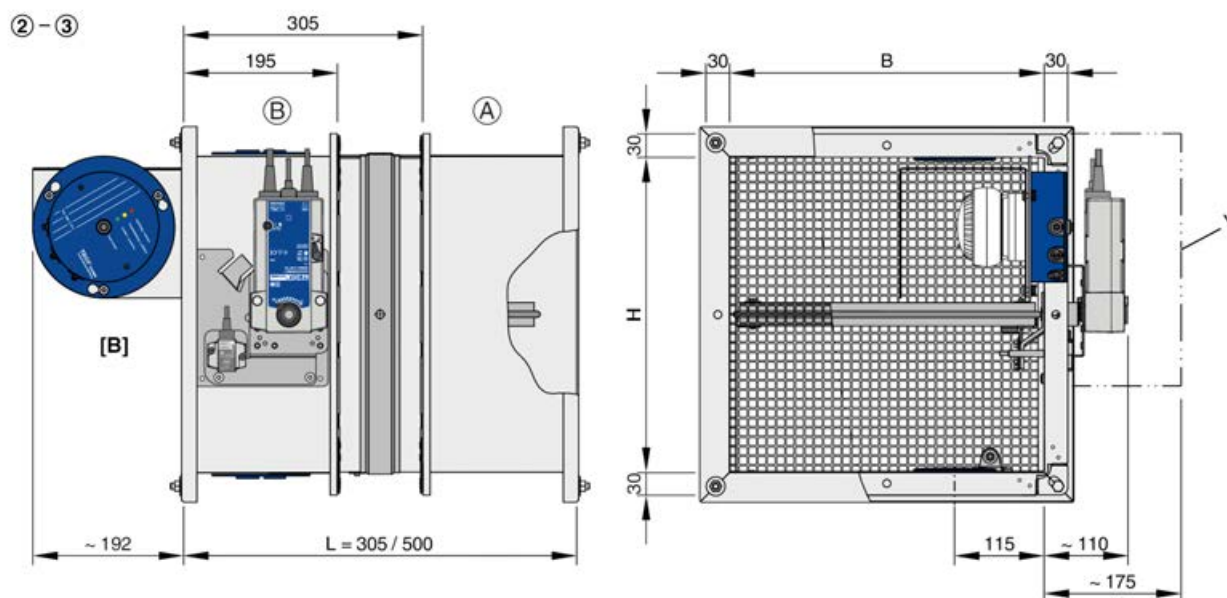

Fig. 10: FK2-EU with spring return actuator and duct smoke detector as air transfer damper – variant with bracket on the drive side, top right (shown for sizes 2 and 3)

| | | | |
|-----|---|-----|--|
| B | Width of the fire damper (side B) | [B] | Spring return actuator vertical |
| H | Height of the fire damper (side H) | Y | Keep clear to provide access for operation |
| FL | Length of the fire damper (casing length) | Ⓐ | Installation side |
| [A] | Spring return actuator horizontal | Ⓑ | Operating side |

- For technical data of the spring return actuator see table 14 and 16
- For sizes 1 to 3 and orientation of the spring return actuator [A] or [B] see table 11.
- Install duct smoke detector RM-O-3-D in the lower inspection access opening and at the top when installing the fire damper. For technical details of the duct smoke detector see the RM-O-3-D operating and installation manual.

The variant with bracket is intended for installation just below the ceiling. In this case the duct smoke detector is to be fitted at the top right, left or centrally in front of the cover grille, see . It can be mounted on the drive side or on the non-drive side.

- If you install the air transfer damper in a ceiling, the size of FK2-EU must not exceed $B \times H = 500 \times 500$ mm.

3 Supply package, transport and storage

Supply package

If attachments and accessories are supplied from the factory with the fire dampers, they are already taken into account in the order code.

Depending on the installation situation, supplementary materials for assembly and fixing may be needed to ensure proper installation, e.g. mortar, screws, mineral wool, etc.

Such materials are not included in the supply package, unless they are expressly described as included in the supply package.

The selection of additional attachments or accessories as well as the identification and provision of materials for assembly and fixing is the responsibility of those involved in the building project and must be done taking into account the required classification.

Delivery check

Check delivered items immediately after arrival for transport damage and completeness. In case of any damage or an incomplete shipment, contact the shipping company and your supplier immediately.

- Fire damper
 - Attachments/accessories, if any
- Operating manual (1 per shipment)



Colour hues on the damper blade

The blades of fire dampers are treated with a greenish impregnating agent. Resulting colour hues on the damper blade are due to technical reasons and do not constitute a defect of any kind.

Transport on site

If possible, take the product in its transport packaging up to the installation location.

Bearing

For temporary storage please note:

- Remove any plastic wrapping.
- Protect the product from dust and contamination.
- Store the product in a dry place and away from direct sunlight.
- Do not expose the unit to the effects of weather (not even in its packaging).
- Do not store the product below -40 °C or above 50 °C.

Packaging

Properly dispose of packaging material.

4 Installation

4.1 Installation situations

Note

The performance classes of the fire damper and the wall or ceiling slab may differ. The lower performance class determines the performance class of the overall system.

| Installation situations | | | | | | |
|-------------------------|--|------------------------|---|--|-----|---------|
| Supporting construction | Installation location | Minimum thickness [mm] | Class of performance EI TT (v _e -h _o , i ↔ o) S up to | Installation type/casing length L [mm] | | Chapter |
| | | | | 305 ¹ | 500 | |
| Solid walls | in | 150 | EI 240 S | N | N | ↳ 44 |
| | | 100 | EI 120 S | N | N | ↳ 44 |
| | | 100 | EI 90 S | N | N | ↳ 44 |
| | | 80 ² | EI 90 S | N | N | ↳ 44 |
| | in, combined installation | 100 | EI 90 S | N | N | * |
| | in, multiple installation | 100 | EI 90 S | N | N | * |
| | in, multiple installation common duct | 100 | EI 120 S | – | N | * |
| | | 100 | EI 90 S | – | N | * |
| | in, partly with mineral wool | 100 | EI 90 S | N | N | * |
| | in, installation kit E3 | 100 | EI 120 S | E | – | * |
| | in, installation kit EW | 100 | EI 120 S | – | E | * |
| | in, underneath flexible ceiling joint Installation kit GM | 100 | EI 90 S | – | N | * |
| | on the face of, installation kit WA | 100 | EI 90 S | – | E | * |
| | remote from, wall attachment, installation kit WE | 100 | EI 90 S | – | E | * |
| | remote from, wall penetration, installation kit WE | 100 | EI 90 S | – | E | * |
| | remote from, wall penetration, Installation kit WE 120 | 100 | EI 120 S | – | E | * |
| | in, fire batt | 100 | EI 120 S | W | W | * |
| | | 100 | EI 90 S | W | W | * |
| | in, fire batt, multiple installation | 100 | EI 90 S | W | W | * |
| | in, combined penetration seal | 100 | EI 90 S | W | W | * |

¹) An extension piece may be required

²) Gypsum wallboard to EN 12859

³) Thickness increased near the installation opening

⁴) Cadolto system

⁵) Depending on local conditions

* see the complete operating and installation manual at www.trox-docs.com

N = Mortar-based installation
E = Installation kit
W = Fire batt
E = Dry mortarless installation

| Installation situations | | | | | | |
|--------------------------------------|---|------------------------|---|--|-----|---------|
| Supporting construction | Installation location | Minimum thickness [mm] | Class of performance EI TT (v _e -h _o , i ↔ o) S up to | Installation type/casing length L [mm] | | Chapter |
| | | | | 305 ¹ | 500 | |
| Metal stud walls | in | 94 | EI 120 S | N | N | * |
| | | 94 | EI 90 S | N | N | * |
| | | 94 | EI 60 S | N | N | * |
| | | 94 | EI 30 S | N | N | * |
| | in, combined installation | 94 | EI 90 S | N | N | * |
| | in, multiple installation | 94 | EI 90 S | N | N | * |
| | in, multiple installation, common duct | 94 | EI 120 S | – | N | * |
| | | 94 | EI 90 S | – | N | * |
| | in, installation kit ES | 94 | EI 120 S | – | E | ⚡ 52 |
| | | 94 | EI 90 S | – | E | ⚡ 52 |
| | | 94 | EI 60 S | – | E | ⚡ 52 |
| | | 94 | EI 30 S | – | E | ⚡ 52 |
| | in, with mineral wool | 94 | EI 60 S | – | T | * |
| | in, with fire-rated gypsum board or plasterboard strips | 94 | EI 90 S | – | T | * |
| | in, flexible ceiling joint, installation kit GL | 100 | EI 90 S | – | E | * |
| | remote from, wall penetration, Installation kit WE | 94 | EI 90 S | – | E | * |
| | in, fire batt | 94 | EI 120 S | W | W | ⚡ 55 |
| | | 94 | EI 90 S | W | W | ⚡ 55 |
| | | 80 | EI 60 S | W | W | ⚡ 55 |
| | | 75 | EI 30 S | W | W | ⚡ 55 |
| in, fire batt, multiple installation | 94 | EI 90 S | W | W | * | |
| in, combined penetration seal | 100 | EI 90 S | W | W | * | |
| Timber stud walls | in | 130 | EI 120 S | N | N | * |
| | | 130 | EI 90 S | N | N | * |
| | | 110 | EI 60 S | N | N | * |
| | | 105 | EI 30 S | N | N | * |
| | in, combined installation | 130 | EI 90 S | N | N | * |
| | in, multiple installation | 130 | EI 90 S | N | N | * |

¹) An extension piece may be required

²) Gypsum wallboard to EN 12859

³) Thickness increased near the installation opening

⁴) Cadolto system

⁵) Depending on local conditions

* see the complete operating and installation manual at www.trox-docs.com

N = Mortar-based installation

E = Installation kit

W = Fire batt

E = Dry mortarless installation

| Installation situations | | | | | | |
|--|--|------------------------|---|--|-----|---------|
| Supporting construction | Installation location | Minimum thickness [mm] | Class of performance EI TT (v _e -h _o , i ↔ o) S up to | Installation type/casing length L [mm] | | Chapter |
| | | | | 305 ¹ | 500 | |
| | in, multiple installation, common duct | 130 | EI 90 S | – | N | * |
| | in, installation kit ES | 130 | EI 120 S | E | E | * |
| | | 130 | EI 90 S | E | E | * |
| | | 110 | EI 60 S | E | E | * |
| | | 105 | EI 30 S | E | E | * |
| | in, with mineral wool | 130 | EI 60 S | – | T | * |
| | in, fire batt | 130 | EI 120 S | W | W | * |
| | | 130 | EI 90 S | W | W | * |
| | | 110 | EI 60 S | W | W | * |
| | | 105 | EI 30 S | W | W | * |
| | in, fire batt, multiple installation | 130 | EI 90 S | W | W | * |
| | in, combined penetration seal | 130 | EI 90 S | W | W | * |
| | Half-timbered constructions | in | 140 | EI 120 S | N | N |
| 140 | | | EI 90 S | N | N | * |
| 110 | | | EI 30 S | N | N | * |
| in, combined installation | | 140 | EI 90 S | N | N | * |
| in, multiple installation | | 140 | EI 90 S | N | N | * |
| in, multiple installation, common duct | | 140 | EI 90 S | – | N | * |
| in, installation kit ES | | 140 | EI 120 S | – | E | * |
| | | 140 | EI 90 S | – | E | * |
| | | 110 | EI 30 S | – | E | * |
| in, with mineral wool | | 140 | EI 60 S | – | T | * |
| in, fire batt | | 140 | EI 120 S | W | W | * |
| | | 140 | EI 90 S | W | W | * |
| | | 110 | EI 30 S | W | W | * |
| in, fire batt, multiple installation | | 140 | EI 90 S | W | W | * |
| in, combined penetration seal | | 140 | EI 90 S | W | W | * |
| Solid wood / CLT walls | in | 95 | EI 90 S | N | N | * |

¹) An extension piece may be required

²) Gypsum wallboard to EN 12859

³) Thickness increased near the installation opening

⁴) Cadolto system

⁵) Depending on local conditions

* see the complete operating and installation manual at www.trox-docs.com

N = Mortar-based installation
E = Installation kit
W = Fire batt
E = Dry mortarless installation

| Installation situations | | | | | | |
|--|--|------------------------|---|--|-----|---------|
| Supporting construction | Installation location | Minimum thickness [mm] | Class of performance EI TT (v _e -h _o , i ↔ o) S up to | Installation type/casing length L [mm] | | Chapter |
| | | | | 305 ¹ | 500 | |
| | in, installation kit ES | 95 | EI 90 S | – | E | * |
| | in, with mineral wool | 95 | EI 60 S | – | T | * |
| | in, fire batt | 95 | EI 90 S | W | W | * |
| | in, combined penetration seal | 100 | EI 90 S | W | W | * |
| Shaft wall with metal support structure | in | 90 | EI 90 S | N | N | * |
| | | 80 | EI 90 S | N | N | * |
| | | 75 | EI 30 S | N | N | * |
| | in, combined installation | 90 | EI 90 S | N | N | * |
| | in, installation kit ES | 90 | EI 90 S | – | E | * |
| | | 80 | EI 90 S | – | E | * |
| | | 75 | EI 90 S | – | E | * |
| Shaft wall without metal support structure | in, installation kit ES | 40 | EI 90 S | – | E | * |
| Solid ceiling slabs | in | 150 | EI 180 S | N | N | * |
| | | 100 (125) ³ | EI 120 S | N | N | * |
| | in, combined installation | 150 | EI 90 S | N | N | * |
| | in, multiple installation | 100 (125) ³ | EI 90 S | N | N | * |
| | in, concrete base | 100 | EI 120 S | N | N | * |
| | in, concrete base, combined installation | 100 | EI 90 S | N | N | * |
| | in, with concrete base, multiple installation | 100 | EI 90 S | N | N | * |
| | in, hollow concrete block ceilings | 125 | EI 90 S | N | N | * |
| | in, hollow core slabs | 125 | EI 90 S | N | N | * |
| | in, ribbed ceilings | 125 | EI 90 S | N | N | * |
| | in, composite ceilings | 125 | EI 90 S | N | N | * |
| | in, combined with wooden beam ceilings | 125 | EI 90 S | N | N | * |
| | in, combined with solid wood ceiling | 125 | EI 90 S | N | N | * |
| | in, combined, lightweight ceiling ⁴ | 125 | EI 120 S | N | N | * |

¹ An extension piece may be required

² Gypsum wallboard to EN 12859

³ Thickness increased near the installation opening

⁴ Cadolto system

⁵ Depending on local conditions

* see the complete operating and installation manual at www.trox-docs.com

N = Mortar-based installation

E = Installation kit

W = Fire batt

E = Dry mortarless installation

| Installation situations | | | | | | | |
|-------------------------|---|------------------------|---|--|-----|---------|---|
| Supporting construction | Installation location | Minimum thickness [mm] | Class of performance EI TT (v _e -h _o , i ↔ o) S up to | Installation type/casing length L [mm] | | Chapter | |
| | | | | 305 ¹ | 500 | | |
| | on the face of, installation kit WA | 125 | EI 90 S | – | E | * | |
| | underneath (horizontal duct), installation kit WE | 125 | EI 90 S | – | E | * | |
| | above (horizontal duct), installation kit WE | 125 | EI 90 S | – | E | * | |
| | in, fire batt | | 150 | EI 120 S | W | W | * |
| | | | 100 | EI 90 S | W | W | * |
| | in, fire batt, multiple installation | | 150 | EI 90 S | W | W | * |
| Solid wood ceilings | in | 140 | EI 90 S | N | N | * | |
| | in, with additional cladding | 112.5 | EI 90 S | N | N | * | |
| | in, installation kit ES | 140 | EI 90 S | – | E | * | |
| | in, installation kit ES, with additional cladding | 112.5 | EI 90 S | – | E | * | |
| Wooden beam ceilings | in | 167.5 | EI 90 S | N | N | * | |
| | | 155 | EI 60 S | N | N | * | |
| | | 142.5 | EI 30 S | N | N | * | |
| | in, installation kit ES | | 167.5 | EI 90 S | – | E | * |
| | | | 155 | EI 60 S | – | E | * |
| | | | 142.5 | EI 30 S | – | E | * |
| | in, historic wooden beam ceilings | | – ⁵ | EI 30 S | N | N | * |

¹⁾ An extension piece may be required

²⁾ Gypsum wallboard to EN 12859

³⁾ Thickness increased near the installation opening

⁴⁾ Cadolto system

⁵⁾ Depending on local conditions

* see the complete operating and installation manual at www.trox-docs.com

N = Mortar-based installation

E = Installation kit

W = Fire batt

E = Dry mortarless installation

4.2 Safety notes regarding installation

Sharp edges, sharp corners and thin sheet metal parts

⚠ CAUTION!

Danger of injury from sharp edges, sharp corners and thin sheet metal parts!

Sharp edges, sharp corners and thin sheet metal parts may cause cuts or grazes.

- Be careful when carrying out any work.
- Wear protective gloves, safety shoes and a hard hat.

4.3 General installation information

! NOTICE!

Risk of damage to the fire damper

- Protect the fire damper from contamination and damage.
- Cover openings and release mechanism (e.g. with plastic) to protect them from mortar and dripping water.
- Do not remove the transport and installation protection (if any) until installation is complete.

- Control elements, electric actuator and inspection access panel must remain accessible for maintenance.
- Loads imposed on the casing may impair the function of the fire damper. Install and connect the damper in such a way that no loads will be imposed on the installed damper. Ducts of combustible or non-combustible materials may be connected to fire dampers if the ducts have been installed straight and without any torsion.
- Before installation: Perform a functional test, then close the fire damper ☞ 65.
- Do NOT remove the product sticker or the adhesive tape in the installation opening.
- Protect the fire damper from humidity and condensation as they will damage the fire damper.
- The construction variants with stainless steel or powder-coated casing and additionally with an impregnated damper blade meet more critical requirements for corrosion protection.
- If the wall or ceiling is very thick, use an extension piece.
- Ensure that the installation of FK2-EU does not reduce the structural safety of the supporting wall or ceiling, not even in the event of a fire.
- The following applies unless stated otherwise in the installation details:

- Fire dampers are to be installed in separate installation openings. Distance between two fire dampers ≥ 200 mm.
- Distance to load-bearing structural elements ≥ 75 mm.
- No more than two fire dampers in the same installation opening.
- With mortar-based installation, fire dampers can be installed at ≥ 40 mm from steel girders, wooden beams or wooden ceilings with fire-rated cladding. The fire-resistant cladding must be manufactured in accordance with a national or European certificate and must have full surface contact (no cavities) with the supporting structure.

- If several fire dampers are used on the same duct, the following has to be ensured: If one damper closes, the maximum permitted upstream velocity for the other fire dampers that remain open must not be exceeded. This has to be ensured by others; it can be ensured, for example, by switching off the fan or by using actuators with limit switches that ensure that not too many dampers close at the same time.

- As ducts may expand and walls may become deformed in the event of a fire, we recommend using flexible connectors for the following installation situations:

- Lightweight partition walls
- Lightweight shaft walls
- Fire batt systems

The flexible connectors should be installed in such a way that they absorb both tension and compression. Flexible ducts can be used as an alternative.

Ducting must be installed in such a way that it does not impose any significant loads on the fire damper in the event of a fire. This can be achieved by a non-straight duct, i.e. by bends or elbows, for example. Be sure to comply with the relevant national guidelines and regulations.

- The interior of the fire damper must be accessible for maintenance work and cleaning. Type FK2-EU fire dampers actually have two inspection accesses. Depending on the installation configuration it may be necessary to provide additional inspection access points in the connecting ducts.
- Load-bearing structures
This includes solid ceiling slabs, concrete beams and load-bearing solid walls.
- Distance to fire-rated partitions
The minimum distances between a partition and other openings or installations, e.g. fire dampers, are usually given in the usability certificates of each partition. In addition, the DIBt has in May 2018 regulated minimum distances between fire-rated partitions and other openings, see www.DIBt.de. There must be no partition next to a fire damper installation (installation into a separate installation opening).

After installation

- Clean the fire damper.
- Remove transport and installation protection or the prop, if any. In case of mortar-based installation this protection must not be removed until the mortar has hardened.
- Test the function of the fire damper.
- Connect the ductwork.
- Make electrical connections.

Equipotential bonding

The flange of the fire damper can be used for equipotential bonding; no holes must be drilled into the damper casing.

In the event of a fire, loads from the equipotential bonding must not affect the fire damper.

Thermal insulation

As suitable insulating materials, especially for outdoor air or exhaust air components, you can use fully bonded panels made of elastomer foams (synthetic rubber), e.g. Armaflex Ultima from Armacell. Be sure to comply with the relevant national guidelines and regulations for combustible building materials and smoke development classes.

Insulation is non-hazardous in terms of fire safety if the following requirements are met:

- The insulation does not impair the function of the fire damper.
- The fire damper remains accessible.
- The inspection accesses remain accessible.
- The insulation does not penetrate walls or ceilings.

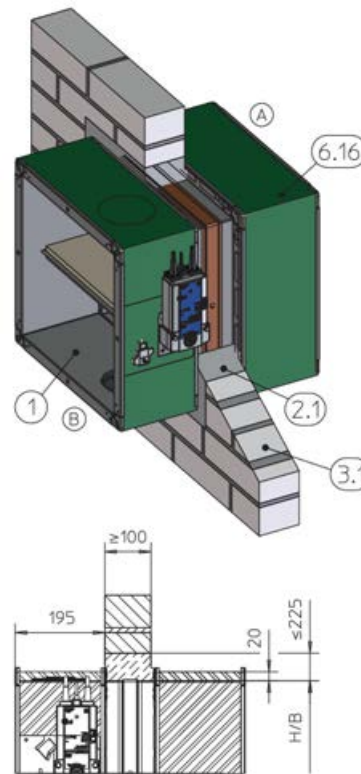

GR3418952, D

Fig. 11: Thermal insulation

- 1 FK2-EU
- 2.1 Mortar
- 3.1 Solid wall
- 6.16 Perimeter insulation (elastomer foam, flame-resistant, non-dripping); actuator and release mechanism, inspection accesses and product sticker must be accessible

Note: The installation situation shown applies to all supporting constructions.

For installation in Germany please note:

In Germany, the MVV TB (since 2019/1) allows only insulation materials with a fire behaviour of at least C - s2, d0. This requirement is met by Armaflex Ultima insulation material from Armacell, for example. The applicable local building regulations must be complied with. For information on the use of elastomer foams see  'If this fire damper is used in Germany:' on page 6.

Extension pieces

To ensure that the fire damper can be connected to the ductwork after installation even if the wall or ceiling is fairly thick, you should extend the fire damper with a suitable extension piece (attachment or by others) on the installation side.

Installation positions

The fire damper may be installed so that the damper blade shaft is horizontal or vertical. The position of the release mechanism is not critical but the mechanism must remain accessible for maintenance (take application-specific restrictions into account).

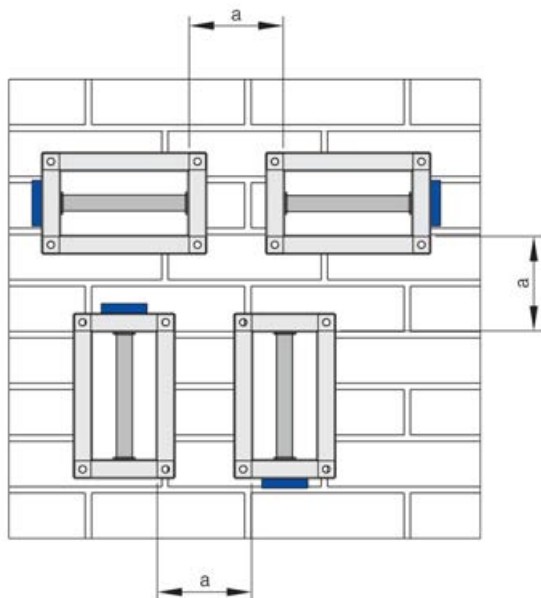

Fig. 12: Blade shaft horizontal or vertical

- a Minimum distance between two fire dampers. Each fire damper is to be installed in its own installation opening unless stated otherwise in the installation details. Distance between two fire dampers \geq 200 mm.

If the fire damper with a duct smoke detector is used in a ventilation system, it must be installed horizontally, with the duct smoke detector at the top.

You may choose a different arrangement as long as you comply with the general building inspectorate licence for the duct smoke detector.

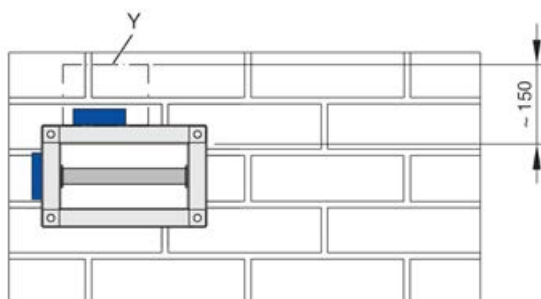
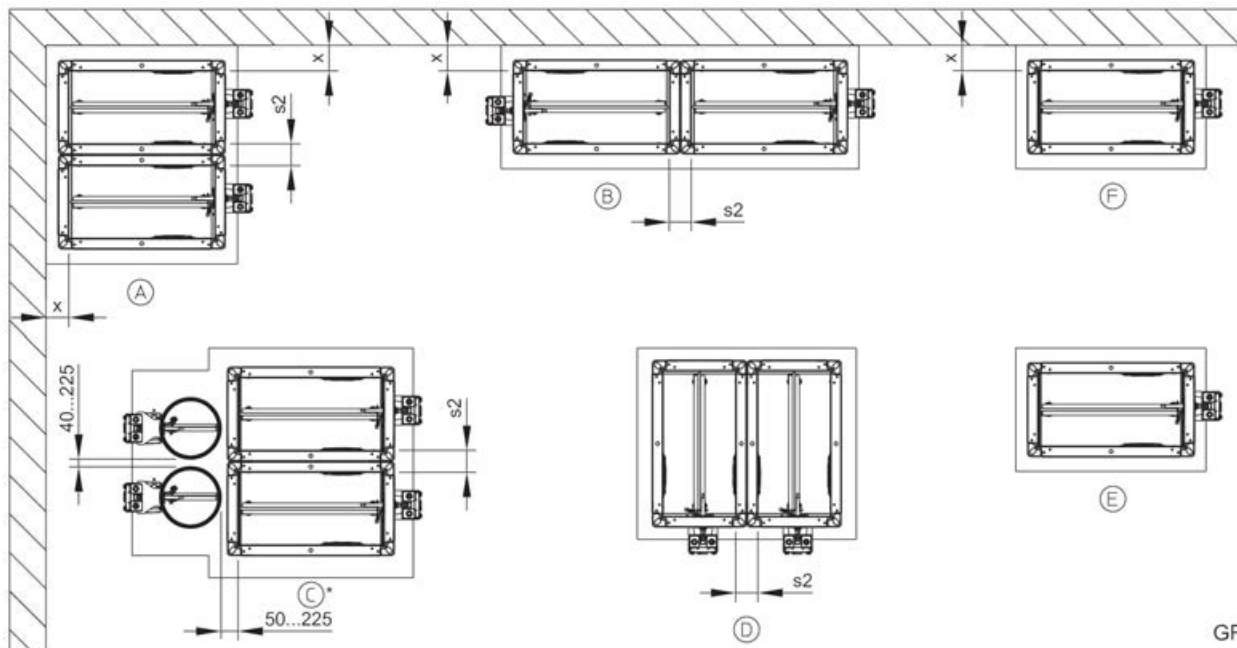

Fig. 13: Horizontal installation

- Y Keep clear for operation and maintenance

Distances



GR3549763, A

Fig. 14: Distances

* Combined installation with fire damper FKRS-EU

Distances (unless stated otherwise in the installation details)

| Installation type | x [mm] | s2 [mm] |
|--------------------------------|----------|--|
| Mortar-based installation | 40 – 225 | 60 ³ – 225 |
| Fire batt installation | 40 – 600 | 60 – 600 ^{2,3} / ≥ 200 ² |
| Partial mortaring ¹ | ~ 50 | 60 ³ – 225 |

¹ Solid wall only

² Depending on supporting structure

³ if L = 500 mm.

If L = 305 mm and installation of dampers on top of each other, the distance has to be 75 – 225 mm (mortar-based installation) or 75 – 600 mm (fire batt installation).

Perimeter gap s1: ≤ 225 mm with mortar-based installation, 40 – 600 mm with fire batt installation.

Installation orientation (see installation details for fire resistance)

| Supporting construction | Installation type | | |
|--|---------------------------|-------------------------|------------------------|
| | Mortar-based installation | Mortarless installation | Fire batt installation |
| Solid wall | A – F | E | A, B, D – F |
| Gypsum wallboard with W = 80 – < 100 mm | E, F | | |
| Lightweight partition wall / compartment wall with metal support structure | A – F | E, F | A, B, D – F |
| Timber stud wall or half-timbered construction | A – F | E, F | A, B, D – F |
| Solid wood wall / CLT wall | E, F | E, F | E, F |
| Shaft wall | A – F | E, F | |

| Supporting construction | Installation type | | |
|--|---------------------------|-------------------------|-----------------------|
| | Mortar-based installation | Mortarless installation | Firebatt installation |
| Solid ceiling slab | A, B, D – F | | A, B, D – F |
| Combined with a lightweight ceiling (Cadolto system) | A, B, D – F | | |
| In / combined with a solid wood ceiling | E, F / A, B, D – F | | |
| In / combined with a wooden beam ceiling | E, F / A, B, D – F | | |

Perimeter gap »s1«

- With mortar-based installation the perimeter gap s1 must not exceed 225 mm (wall and ceiling). The perimeter gap »s« must be large enough so that mortar can be filled in even in case of thicker walls or ceilings. Be sure to close larger wall openings or holes beforehand and in a suitable way, i.e. depending on the type of wall. In case of larger openings in solid ceiling slabs, the dampers can be concreted in as the ceiling is being constructed. The gap must be large enough so that mortar can be filled in. We recommend a gap of at least 20 mm (note the minimum installation opening size). Reinforcement should meet structural requirements.

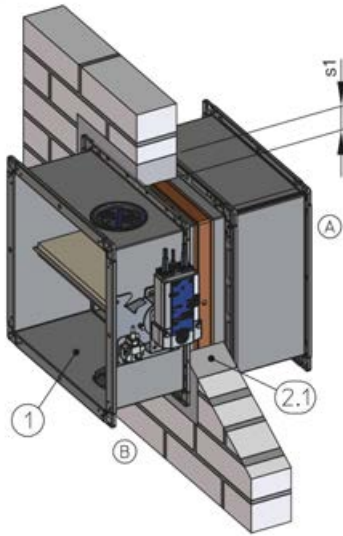

GR3476383, A

Fig. 15: Perimeter gap

- 1 FK2-EU
- 2.1 Mortar
- s1 Perimeter gap

Maximum gap widths are based on EN 15882-2. Larger gaps do not have an adverse effect with regard to fire protection and are in our opinion not critical.

Mortar-based installation

- Cover all openings and control elements of the fire damper (e.g. with plastic) to protect them from contamination.
- In case of mortar-based installation it may be necessary to protect the sides of the fire damper casing against deformation, e.g. with a prop.
- Position the fire damper in the centre of the installation opening, then push it in so that the distance between the operating side flange and the wall or ceiling is 195 mm; secure the fire damper in this position. Connect extension piece, if required, or duct.
- In case of mortar-based installation, the open spaces between the fire damper casing and the wall or ceiling slab must be closed off with mortar. Entrapped air is to be avoided. The mortar bed depth should be equal to the thickness of the wall but must be at least 100 mm.
- If you install the fire damper as the solid wall or ceiling slab is being completed, perimeter gap »s1« is not required. The open spaces between the fire damper and the wall must be closed off with mortar; for installation into solid ceiling slabs, use concrete. Reinforcement should meet structural requirements.
- The mortar bed depth should be equal to the thickness of the wall. If trim panels with appropriate fire resistance are used, a mortar bed depth of 100 mm suffices.

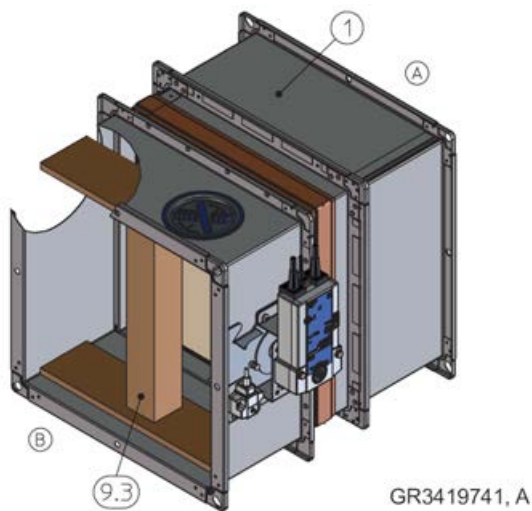

Fig. 16: FK2-EU with prop

- 1 FK2-EU
- 9.3 Prop

Mortar

- DIN 1053: Groups II, IIa, III, IIIa; fire protection mortar of groups II, III
- EN 998-2: Classes M 2.5 to M 20 or fire protection mortar of classes M 2.5 to M 20
- Equivalent mortars that meet the requirements of the above standards, gypsum mortar or concrete

Mineral wool as filling material

Unless otherwise stated in the installation details, mineral wool with a gross density of $\geq 80 \text{ kg/m}^3$ and a melting point of $\geq 1000 \text{ }^\circ\text{C}$ must be used.

Fire-resistant cladding

When you use installation kit WE, the following materials are acceptable for the cladding of fire dampers and ducts:

- Promatect® LS35
- Promatect® L500
- Promatect® AD40

Installation with installation kit ES

- Casing length $L = 500 \text{ mm}$
- The installation kit has to be attached to the fire damper (by others).
- Enough clear space is required for mounting the installation kit onto the fire damper.
- Use dry wall screws $\varnothing 5.5 \text{ mm}$ and brackets to fix the installation kit ES; make sure that the dry wall screws are long enough so that they can be firmly fastened to the studs. The dry wall screws must be long enough so that the damper can be firmly fastened. The holes for the fixing screws on side B are made in the factory.
- For installation near the floor or ceiling, professionally shorten the cover plate on the installation kit on one side. Then use the brackets that were previously on sides B and fix them in the upper parts of sides H (see installation details). Pre-drill the holes $\varnothing 4 \text{ mm}$.

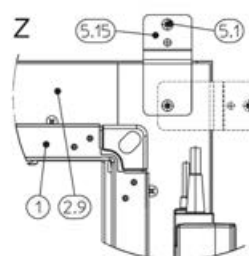
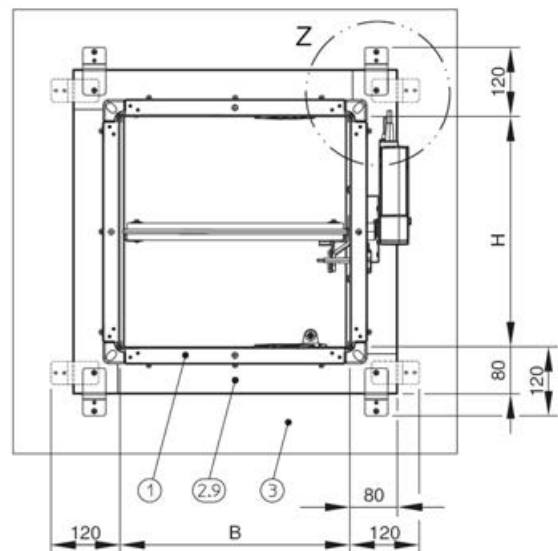

GR3513999, A

Fig. 17: Installation kit – clear space, normal installation

- 1 FK2-EU
- 2.9 Installation kit ES
- 3 Wall
- 5.1 Dry wall screw (by others)
- 5.15 Bracket

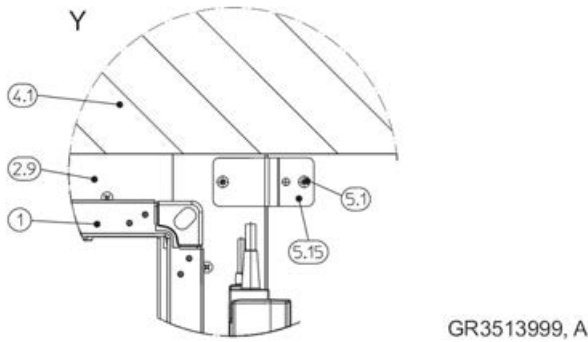
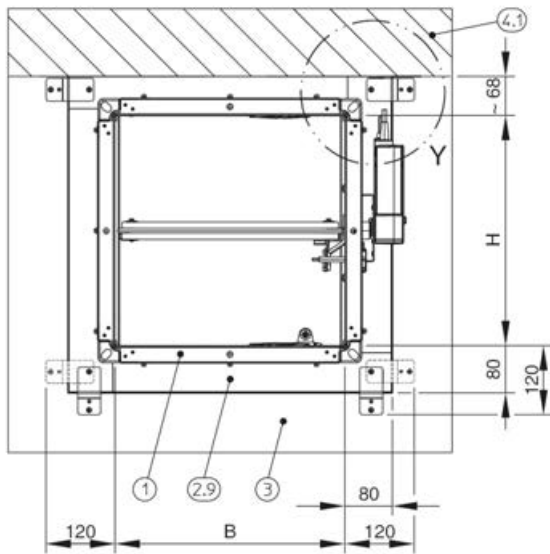

Fig. 18: Installation kit – clear space, for installation near the floor or ceiling

- 1 FK2-EU
- 2.9 Installation kit ES (cover plate shortened by others)
- 3 Wall
- 4.1 Solid ceiling slab / solid floor
- 5.1 Dry wall screw (by others)
- 5.15 Bracket

GR3513999, A

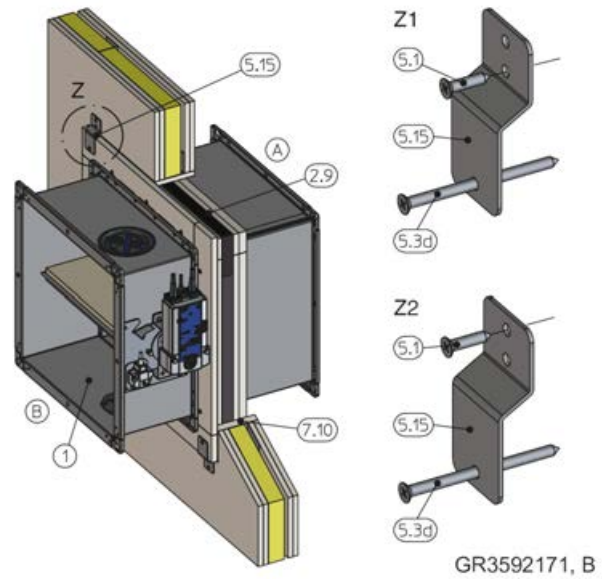

Fig. 19: Fastening the installation kit to the metal studs

- 1 FK2-EU
- 2.9 Installation kit ES
- 5.1 Dry wall screw (by others)
- 5.3d Chipboard screw 5 × 50 mm (up to $B \leq 800$ mm, 4 screws; if $B > 800$ mm, 8 screws)
- 5.15 Bracket (up to $B \leq 800$ mm, 4 brackets; if $B > 800$ mm, 8 brackets)
- 7.10 Trim panels
- Z1 Fastening – without trim panel or with single-layer trim panel
- Z2 Fastening – with double-layer trim panels
- A Installation side
- B Operating side

GR3592171, B

Installation with installation kit E3

- Casing length $L = 305$ mm (with extension pieces on both sides to achieve $L = 500$ mm)
- The installation kit has to be attached to the fire damper (by others).
- For dry mortarless installation into solid walls use the existing installation subframe E1 / E2 of the FK-K90 or FK-EU.

Installation with installation kit EW

- Casing length $L = 500$ mm
- The installation kit has to be attached to the fire damper (by others).
- For dry mortarless installation into solid walls use an installation subframe

Installation with installation kit GM

- Casing length L = 500 mm
- The installation kit has to be attached to the fire damper (by others).
- The installation kit is provided for installation into solid non-load-bearing walls with a flexible ceiling joint.

Installation on the face of solid walls and ceiling slabs with installation kit WA

- Casing length L = 500 mm
- The installation kit has to be attached to the fire damper (by others).
- Enough clear space is required to mount the installation kit onto the fire damper, at least 150 mm around the perimeter. Cladding and wall/ceiling attachment are required on all 4 sides.
- Attach (flange) the fire damper to a sheet steel duct that has been shortened and is flush with the wall or ceiling.
- Alternatively, attach the FK2-EU with the wall face frame to a cut hole or to a circular duct that has been shortened so as to be flush with the wall. The movement of the damper blade must not be impaired.
- Use fire-rated steel anchors with suitability certificate to fix the wall face frame to the wall/ceiling (on a cut hole or circular duct) and also to fix the cladding; push through installation is also possible.
- For more installation details see the various installation situations.

Installation remote from walls and ceilings with installation kit WE

- Casing length L = 500 mm
- The installation kit has to be attached to the fire damper (by others).
- Attach the fire damper to sheet steel ducts with fire-resistant cladding and without any openings.
- Wall or ceiling attachment, wall or ceiling penetration, suspension of the fire damper and attachment of the cladding to the installation kit have to be carried out as described in this manual. Suspension and cladding of the duct, including fittings, have to be carried out according to Promat[®] specifications.
- Cladding and wall/ceiling attachment are required on all 4 sides. Enough clear space is required, at least 155 mm around the perimeter.
- Fire dampers installed remote from walls and ceilings need to be suspended or fixed, see [Chapter 4.6.2 'Suspending fire dampers installed remote from solid walls and ceiling slabs' on page 60](#).
- Suspension systems with $L \geq 1.5$ m require fire-resistant insulation. Use cladding or mineral wool insulation according to the manufacturer's specifications.
- For more information on installation and components to be provided by others see the descriptions of the various installation situations and the Promat manual.

Installation remote from walls and ceilings with installation kit WE 120

- Casing length L = 500 mm
- The installation kit has to be attached to the fire damper (by others).
- Attach the fire damper to sheet steel ducts with PAROC[®] mineral wool insulation and without any openings.
- Wall attachment, wall penetration, suspension of the fire damper and attachment of the mineral wool insulation to the installation kit have to be carried out as described in this manual. Attaching the mineral wool insulation to the duct, including fittings, has to be carried out as described in this manual and also according to PAROC[®] specifications.
- Mineral wool insulation and wall attachment are required on all 4 sides. Enough clear space is required, at least 180 mm around the perimeter.
- Fire dampers installed remote from walls and ceilings need to be suspended or fixed, see [Chapter 4.6 'Fixing the fire damper' on page 59](#) [4.6.3 'Fixing the damper when a fire batt is used' on page 61](#).
- Suspension systems with $L \geq 1.5$ m require fire-resistant insulation. Use cladding or mineral wool insulation according to the manufacturer's specifications.

Installation into lightweight partition walls with metal support and flexible ceiling joint with installation kit GL / GLK

- Casing length L = 500 mm
- The installation kit has to be attached to the fire damper (by others).
- Enough clear space is required for mounting the installation kit onto the fire damper.
- Fixing installation kit GL/GLK: Use threaded rods M10, approx. 130 mm long, with nuts, and steel brackets, approx. 50 × 40 × 5 mm (supply package).
- Fixing the installation kit to the ceiling: Use fire-rated steel anchors with suitability certificate, at least M8, or alternatively threaded rods (push through).
- For more installation details see the various installation situations.

Installation with fire batt

- The distance from the operating side flange to the wall has to be 195 mm.
- Fire batt systems consist of two layers of mineral wool slabs, gross density $\geq 140 \text{ kg/m}^3$.
- Apply fire-resistant sealant to the cut faces of the mineral wool slabs and fit them tightly into the installation opening. Seal any gaps between the mineral wool slabs and the installation opening, gaps between the cut faces of cut-to-size pieces, and gaps between slabs and the fire damper by applying fire-resistant sealant or coating. Use only sealant or coating that is suitable for the fire batt system.
- Apply ablative coating to the mineral wool slabs, joints, transitions and any imperfections on the coated mineral wool slabs; coating thickness $\geq 2.5 \text{ mm}$.
- Do not use a fire batt in combination with a flexible ceiling joint.
- Fix fire dampers on both sides of the wall.
- If the ceiling is fairly thick, you may use additional layers of mineral wool slabs on side A.

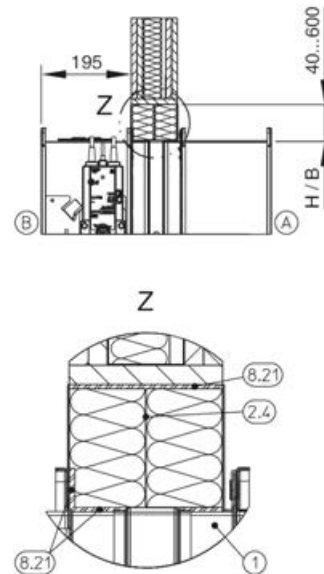

GR3386448, B

Fig. 20: Fire-resistant sealant

- 1 FK2-EU
- 2.4 Coated board system
- 8.21 Firestop sealant
- A Installation side
- B Operating side

Fire batt systems

The following fire batt systems are acceptable (fire batt systems have to be provided by others). As for mineral wool slabs, all slabs that are part of the system and have been approved by the manufacturer may be used.

Promat[®]

- Ablative coating Promastop[®]-CC
- Ablative coating Promastop[®]-I
- Ablative coating Intumex-CSP
- Ablative coating Intumex-AC

Hilti

- Ablative coating CFS-CT
- Ablative coating CP 673
- Fire-resistant sealant CFS-S ACR

HENSEL

- Ablative coating HENSOMASTIK[®] 5 KS Farbe
- Fire-resistant sealant HENSOMASTIK[®] 5 KS Spachtel

SVT

- Ablative coating PYRO-SAFE FLAMMOTECT-A Farbe
- Fire-resistant sealant PYRO-SAFE FLAMMOTECT-A Spachtel

OBO Bettermann

- Ablative coating PYROCOAT[®] ASX Farbe
- Fire-resistant sealant PYROCOAT[®] ASX Spachtel

Würth

- Ablative coating Würth Ablationsbeschichtung I ('Ablation coating I')

AGI

- Ablative coating PYRO-SAFE Flammotect Combi S90
- Fire-resistant sealant AGI Flammotect COMBI S90

Dimensions and distances for fire batt systems for wall installation

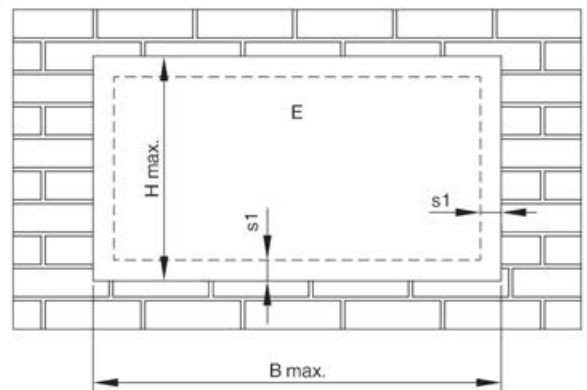

GR3420162, D

Fig. 21: Fire batt – installation in solid walls and ceiling slabs, lightweight partition, timber stud wall, half-timbered construction and solid wood walls

E Installation area

| Coated board system | B max. [mm] | H max. [mm] |
|---------------------|-------------|-------------|
| Promat [®] | ≤ 3750 | ≤ 1840 |
| Hilti | ≤ 3000 | ≤ 2115 |
| Hensel | ≤ 1900 | ≤ 1400 |
| SVT | | |
| OBO Bettermann | | |
| Würth | | |
| AGI | | |

| Damper combination up to EI 90 S | s1 min. [mm] | s1 max. [mm] |
|----------------------------------|--------------|--------------|
| FK2-EU | 40 | 600 |

Requirements for wall and ceiling systems

FK2-EU fire dampers may be installed in wall and ceiling systems if these walls and ceilings have been erected in compliance with the relevant regulations, and if the information on the respective installation situation applies and the following requirements are met.

Provide any installation openings according to the installation details in this manual.

The structural safety of the wall/ceiling must be ensured (by others). Compensation measures, especially with regard to large installation openings, must be determined on a case to case basis (by others).

Solid walls

- Solid walls or compartment walls made of, for example, concrete, aerated concrete, masonry or solid gypsum wallboard to EN 12859, (without cavities), gross density $\geq 350 \text{ kg/m}^3$.
- Wall thickness $W \geq 100 \text{ mm}$.
- Provide each installation opening and cut hole according to the local and structural conditions and with regard to the size of the fire damper.
- Cavities, e.g. in hollow concrete blocks or created in the supporting structure as a consequence of wall penetrations or cutting holes, must be filled before the installation of the fire damper so that the fire resistance of the supporting structure is restored.

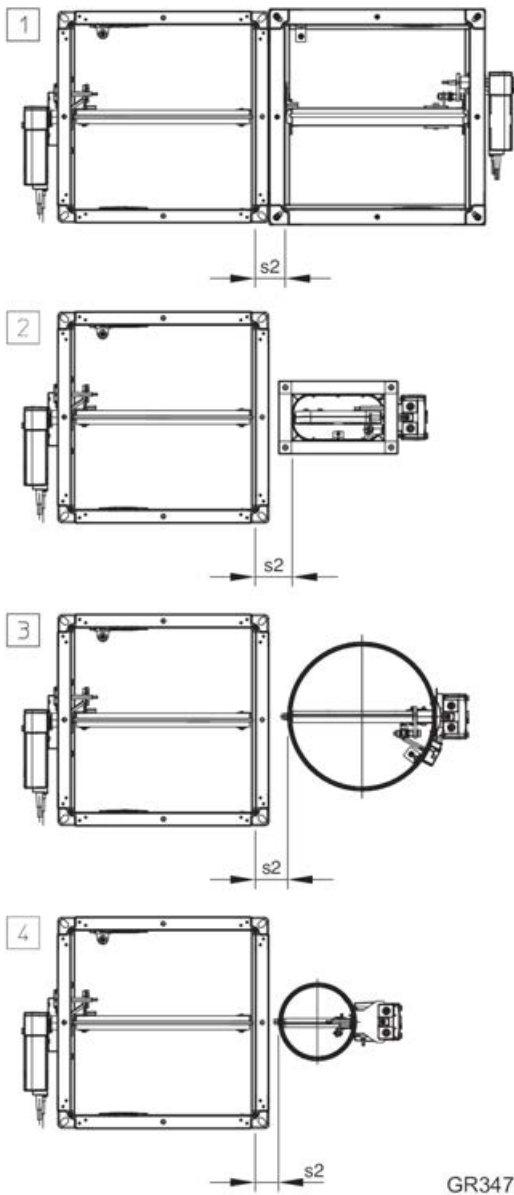

Fig. 22: Distance between FK2-EU and other TROX fire dampers in mortar-based installation

Distance between different TROX fire dampers – mortar-based installation into solid walls (one installation opening)

| No. | Damper combination up to EI 90 S | s2 [mm] |
|-----|----------------------------------|--|
| 1 | FK2-EU – FK-EU | 65 – 225 |
| 2 | FK2-EU – FKS-EU | 80 – 150 |
| 3 | FK2-EU – FKR-EU | 70 – 225 (80 – 225, flange construction) |
| 4 | FK2-EU – FKRS-EU | 50 – 225 |

Gypsum wallboard

- Gypsum wallboard according to EN 12859 (without cavities).
- Wallboard thickness $W \geq 80 \text{ mm}$, if $W \geq 100 \text{ mm}$ see [on page 40](#).
- Provide each installation opening according to the local and structural conditions and with regard to the size of the fire damper.

Lightweight partition walls with metal support structure

- Lightweight partition walls, safety partition walls or walls to provide radiation protection, with metal support structure or steel support structure (box sections), with European classification to EN 13501-2 or equivalent national classification.
- Cladding on both sides made of gypsum bonded or cement bonded panel materials, fibre-reinforced gypsum or fire-rated calcium silicate boards.
- Wall thickness $W \geq 94 \text{ mm}$, for compartment walls or safety partition walls $W \geq 100 \text{ mm}$.
- Distance between metal studs $\leq 625 \text{ mm}$; distance between metal studs for compartment walls $\leq 312.5 \text{ mm}$.
- Compartment walls and safety partition walls may be provided with sheet steel inserts and may require less space between the metal studs.
- Create an installation opening with trimmers (studs and noggings).
- If necessary, provide trim panels and screw-fix them to the support structure
- Additional layers of cladding (if stated in the usability certificate for the wall) and double stud constructions are approved.
- Connect the metal sections near the installation opening according to the installation details in this manual.
- If reinforcing boards are required, screw-fix them to the metal support structure at intervals of approx. 100 mm.
- Installation only in non-load-bearing walls (load-bearing wall constructions on request).

Lightweight partition walls with timber support structure / half-timbered construction

- Lightweight partition walls, either timber stud walls or half-timbered constructions, with European classification to EN 13501-2 or equivalent national classification.
- ≤ 625 mm distance between timber studs; half-timbered constructions ≤ 1000 mm
- Cladding on both sides made of gypsum bonded or cement bonded panel materials, fibre-reinforced gypsum or fire-rated calcium silicate boards.
- Wall thickness $W \geq 130$ mm ($W \geq 110$ with F60, $W \geq 105$ with F30); wall thickness of half-timbered constructions $W \geq 140$ mm ($W \geq 110$ with F30).
- Erect the timber stud wall or half-timbered construction according to the manufacturer's instructions.
- Additional layers of cladding (if stated in the usability certificate for the wall) and double stud constructions are approved.
- Create an opening in the timber support structure with studs and trimmers.
- Trim panels and reinforcing boards have to be made of cladding material and have to be fixed to the frame.

Solid wood walls

- Fire-resistant solid wood walls or cross laminated timber walls with European or national certificate.
- Wall thickness $W \geq 95$ mm (with reinforcing board $W \geq 100$ mm near the installation opening).
- If required, additional gypsum bonded or cement bonded panel materials or fibre-reinforced gypsum board are permitted.

Shaft walls with metal support structure

- Shaft walls or additional leaves with metal support structure or steel support structure (box sections), with European classification to EN 13501-2 or equivalent national classification.
- Cladding on one side made of gypsum bonded or cement bonded panel materials, fibre-reinforced gypsum or fire-rated calcium silicate boards.
- Wall thickness $W \geq 90$ mm, cladding $\geq 2 \times 20$ mm ($W \geq 75$ mm, cladding $\geq 2 \times 12.5$ mm with F30); cladding / reinforcing boards according to installation details.
- ≤ 625 mm distance between metal studs.
- Be sure to follow the manufacturers' instructions for the height, width and thickness of walls.
- Create an installation opening with trimmers (studs and noggings).
- If necessary, provide trim panels and screw-fix them to the support structure
- Installation with the actuator on the outside of the shaft.
- If reinforcing boards are required, screw-fix them to the metal support structure at intervals of approx. 100 mm.

Shaft walls without metal support structure

- Shaft walls without metal support structure, with European classification according to EN 13501-2 or equivalent national classification.
- Cladding on one side made of gypsum bonded or cement bonded panel materials, fibre-reinforced gypsum or fire-rated calcium silicate boards.
- Shaft wall between two solid walls, without corners
- Wall thickness $W \geq 50$ mm.
- If reinforcing boards are required, screw-fix them to the metal support structure at intervals of approx. 100 mm.

General installation information

Solid ceiling slabs

- Solid ceiling slabs without open spaces, made of concrete or aerated concrete, gross density $\geq 450 \text{ kg/m}^3$.
- Ceiling thickness $D \geq 100 \text{ mm}$, thickness increased to $D \geq 125 \text{ mm}$ where required (unless stated otherwise in the installation details).
- Partial solid ceiling slab, thickness $\geq 125 \text{ mm}$, combined with a fire-resistant wooden beam ceiling (also glulam), solid wood ceiling or lightweight ceiling (Cadolto system only).
- Provide each installation opening according to the local and structural conditions and with regard to the size of the fire damper.
- Other ceiling types:
 - Hollow concrete block ceilings, $D \geq 125 \text{ mm}$
 - Hollow core slabs, $D \geq 125 \text{ mm}$
 - Ribbed ceilings, $D \geq 125 \text{ mm}$ (thickness increased where required)
 - Composite ceilings, $D \geq 125 \text{ mm}$

Solid wood ceilings

- Solid wood or cross-laminated timber ceilings.
- Ceiling thickness $D \geq 140 \text{ mm}$ or $D \geq 112.5 \text{ mm}$ with supplementary fire-resistant cladding.

Wooden beam ceilings

- Wooden beam or gluelam construction.
- Ceiling thickness $D \geq 142.5 \text{ mm}$ (ceiling-dependent) with supplementary fire-resistant cladding.
- Historical wooden beam ceilings F30.

4.4 Solid walls

4.4.1 General

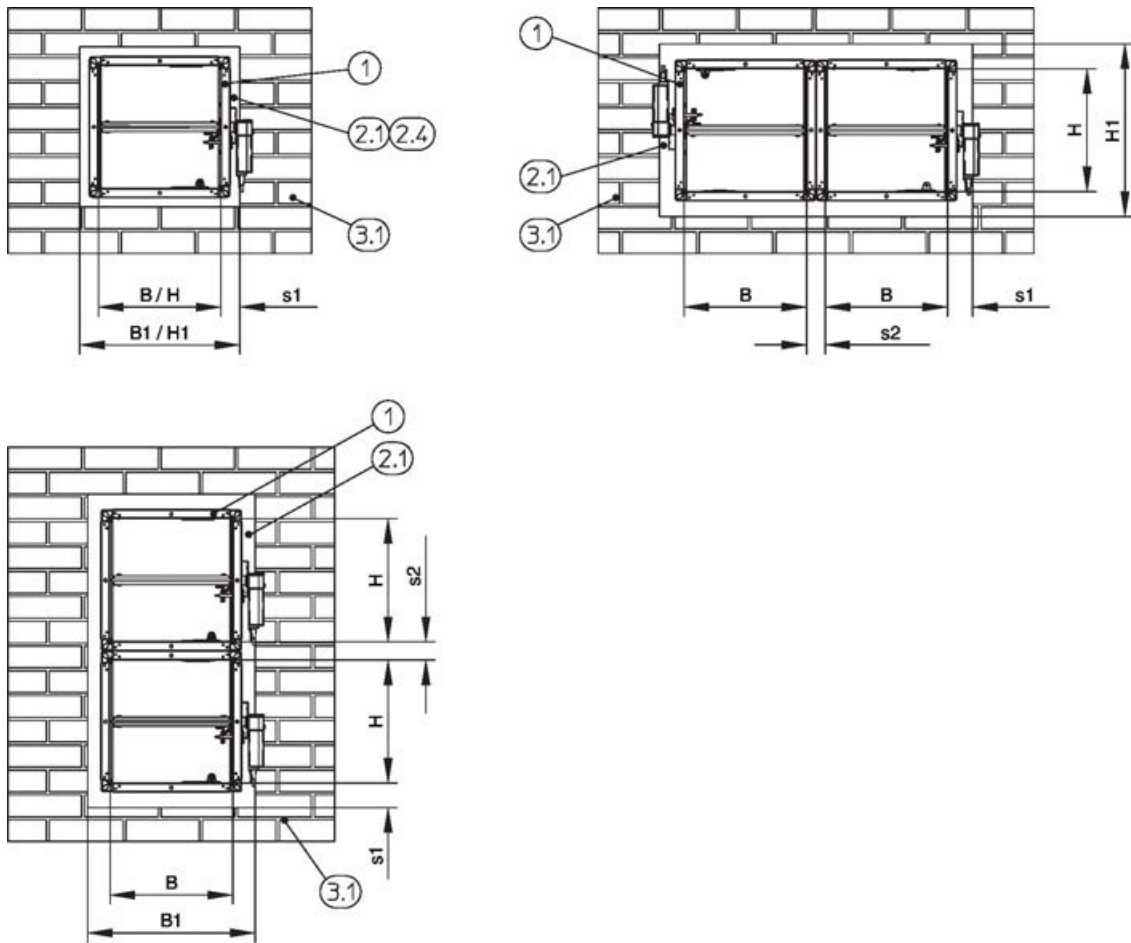

doc_techdraw_003879

Fig. 23: Solid walls – arrangement / distances

- | | | | |
|-----|---------------------|-----|---|
| 1 | FK2-EU | 3.1 | Solid wall |
| 2.1 | Mortar | s1 | Perimeter gap, ↗ on page 34 |
| 2.4 | Coated board system | s2 | Distance between the fire dampers, ↗ 'Distances' on page 33 |

| Installation type | Installation opening [mm] | | Distance [mm] | |
|---|---------------------------|---------------|---------------|-----------------------|
| | B1 | H1 | s1 | s2 |
| Mortar-based installation | B + 450 max. | H + 450 max. | ≤ 225 | 60 ² – 225 |
| Dry mortarless installation with fire batt ¹ | H + 1200 max. | H + 1200 max. | 40 – 600 | 60 ² – 600 |

¹) Note the maximum size for the fire batt

²) With length 305 mm and installation of fire dampers on top of each other, gap s2 has to be at least 75 mm.

Additional requirements: solid walls

- Solid wall, ↗ on page 40
- Distances and installation orientation, ↗ 'Distances' on page 33

4.4.2 Mortar-based installation

Mortar-based installation into a solid wall

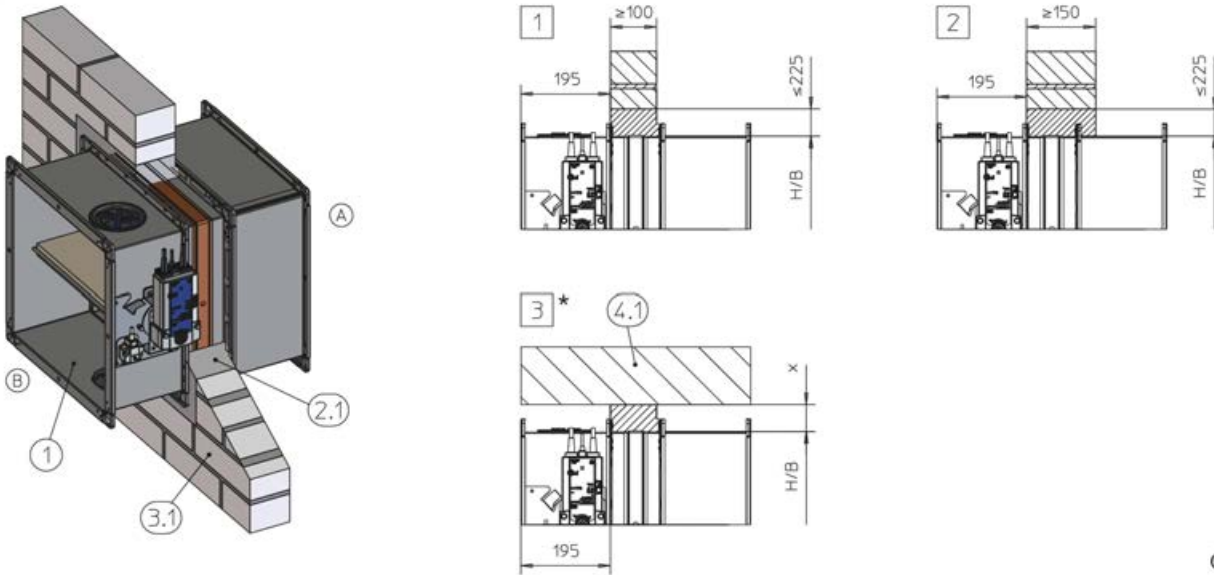

GR3286910, E

Fig. 24: Mortar-based installation into a solid wall

- | | | | |
|-----|-------------------------------------|---|------------------------------------|
| 1 | FK2-EU | 1 | Up to EI 120 S |
| 2.1 | Mortar | 2 | Up to EI 240 S |
| 3.1 | Solid wall | 3 | Up to EI 120 S with $x \geq 40$ mm |
| 4.1 | Solid ceiling slab / solid floor | | Up to EI 240 S with $x \geq 75$ mm |
| * | Installation near the floor as in 3 | | |

Mortar-based installation into a solid wall, flange to flange

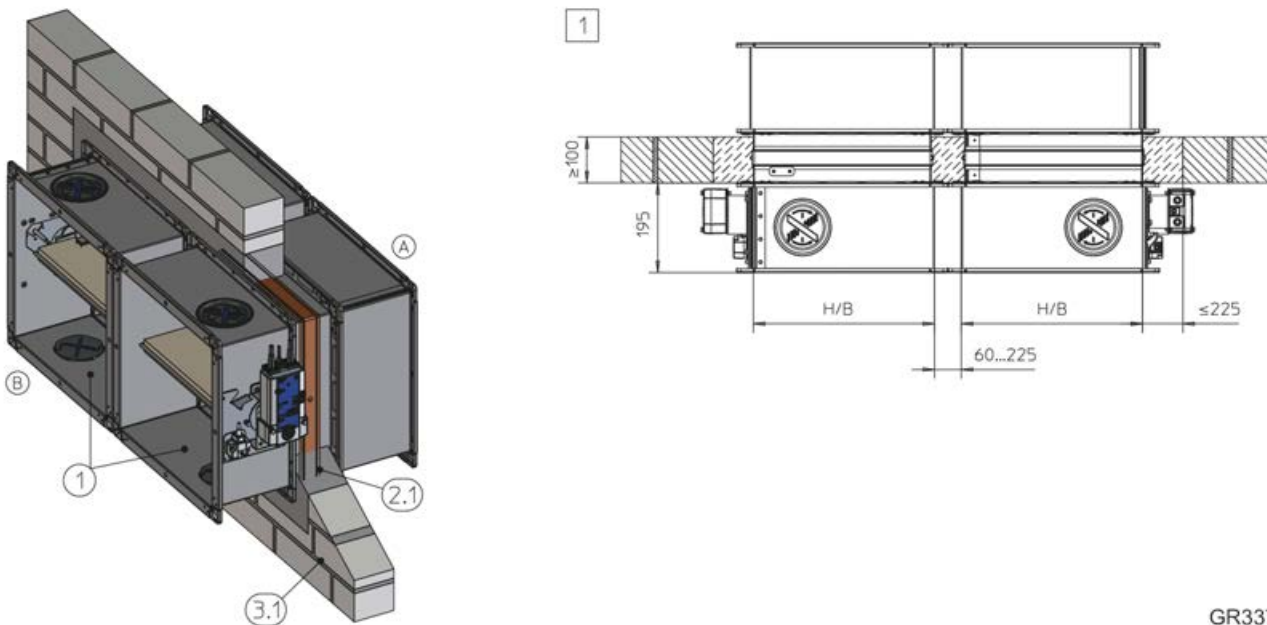

GR3379161, C

Fig. 25: Mortar-based installation into a solid wall, flange to flange, illustration shows side by side installation (applies also to installation of dampers on top of each other)

- | | | | |
|-----|--------|-----|----------------|
| 1 | FK2-EU | 3.1 | Solid wall |
| 2.1 | Mortar | 1 | Up to EI 120 S |

Mortar-based installation into a solid wall

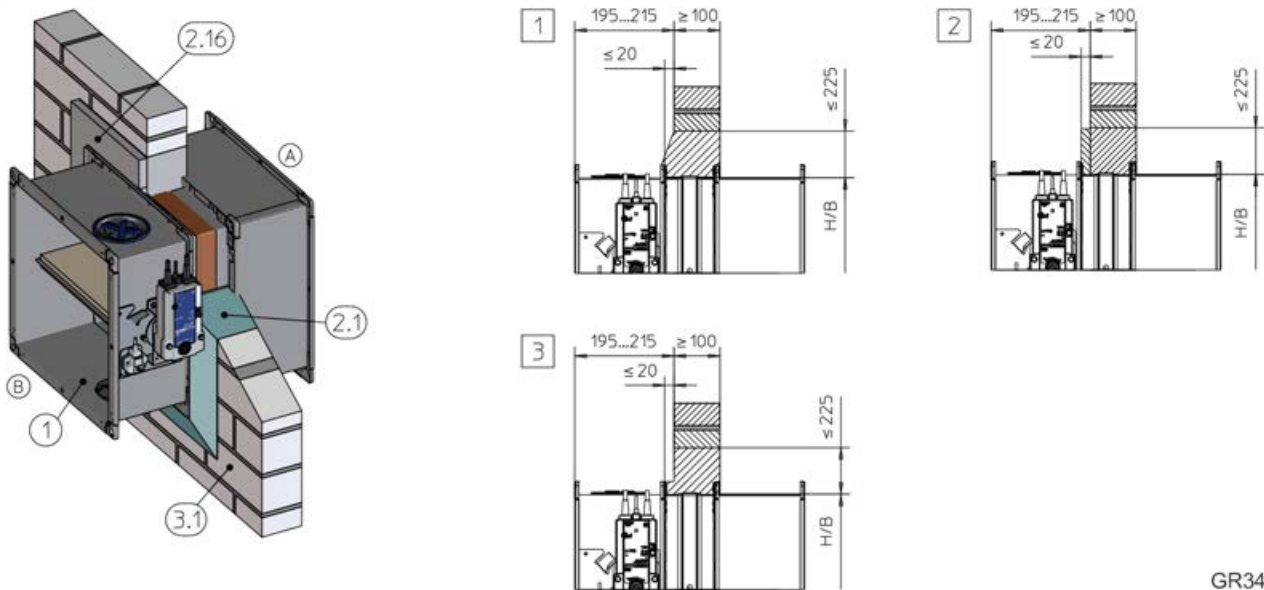

GR3484021, F

Fig. 26: Mortar-based installation into a solid wall

- | | | | |
|------|--|-------|----------------|
| 1 | FK2-EU | 3.1 | Solid wall |
| 2.1 | Mortar, alternatively closing the perimeter gap with mortar and sloping plaster finish | 1 – 3 | Up to EI 120 S |
| 2.16 | Cement plaster | | |

Additional requirements: mortar-based installation into solid walls / gypsum wallboard

- Solid wall / gypsum wallboard, ↗ on page 40
- Casing length L = 305 or 500 mm

4.5 Lightweight partition walls

4.5.1 General

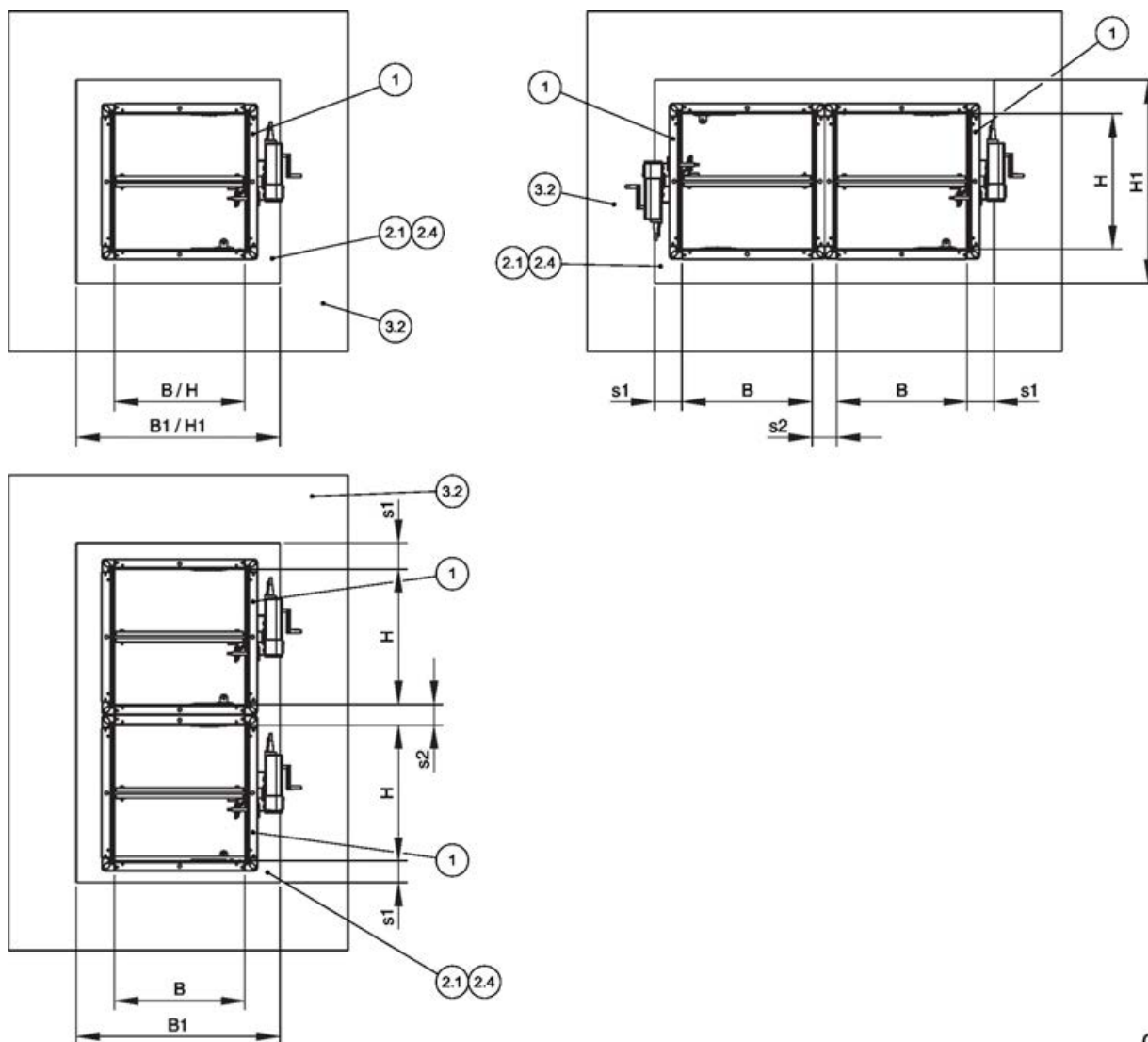

GR3870078, A

Fig. 27: Lightweight partition walls with metal support structure – arrangement/distances

- | | | | |
|-----|---------------------|-----|---|
| 1 | FK2-EU | 3.2 | Lightweight partition wall, cladding on both sides |
| 2.1 | Mortar | s1 | Perimeter gap, ↗ on page 34 |
| 2.4 | Coated board system | s2 | Distance between the fire dampers, ↗ 'Distances' on page 33 |

| Installation type | Installation opening [mm] | | | |
|--|---------------------------|----------------|----------------------|-----------------------|
| | B1 | H1 | s1 | s2 |
| Mortar-based installation ¹ B + 450 max. | | H + 450 max. | ≤ 225 | 60 ⁴ – 225 |
| Dry mortarless installation with installation kit ES ^{1, 2} | B + 140 | H + 140 | central installation | |
| Dry mortarless installation with fire batt ³ | B + 80 to 1200 | H + 80 to 1200 | 40 – 600 | 60 ⁴ – 600 |

¹ Trim panels are optional or according to installation details

² Installation opening tolerance ± 2 mm

³ Trim panels required according to installation details

⁴ With length 305 mm and installation of fire dampers on top of each other, the distance between FK2-EU dampers has to be at least 75 mm.

Lightweight partition wall with metal support structure and cladding on both sides

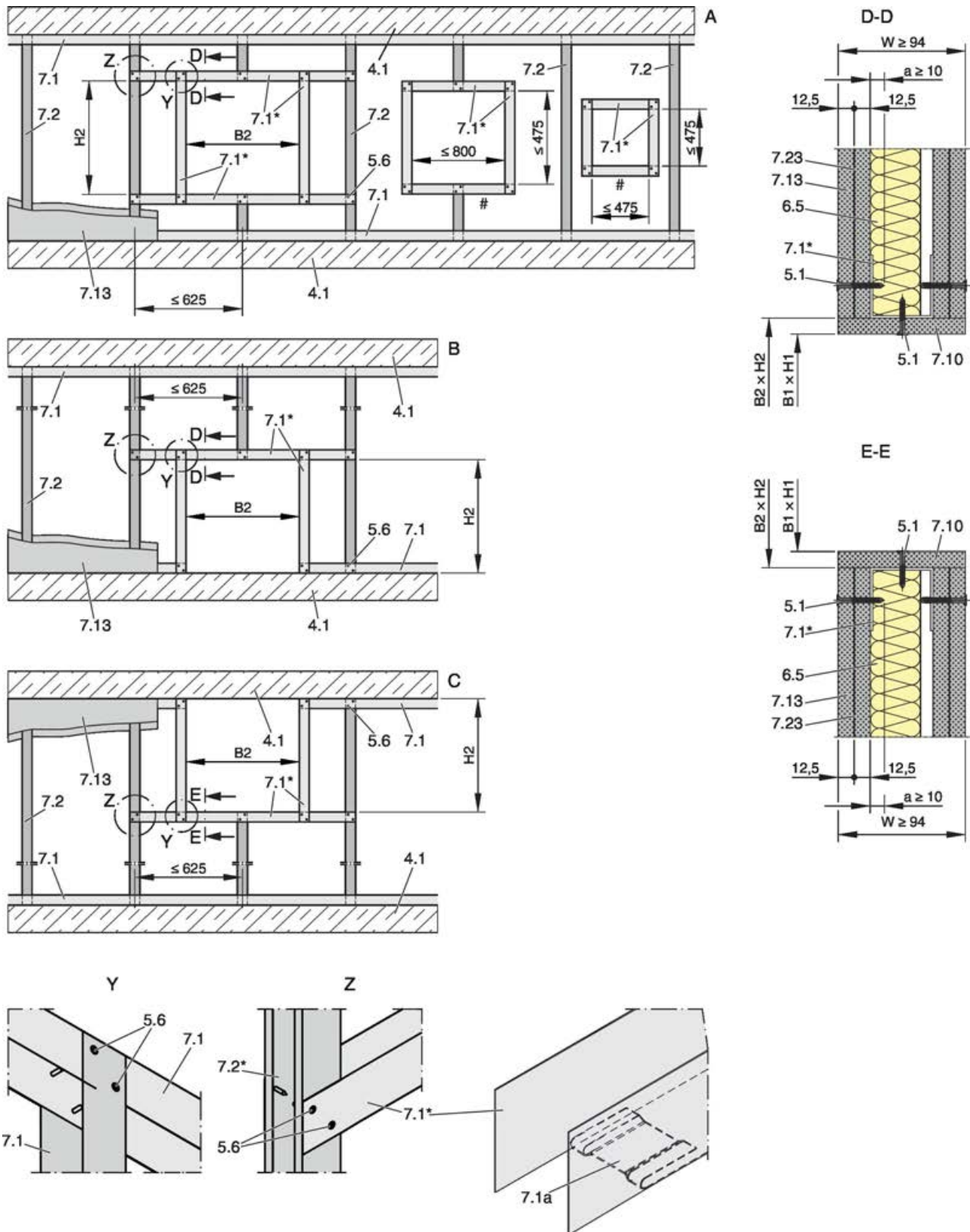

Fig. 28: Lightweight partition wall with metal support structure and cladding on both sides, explanation see Fig. 29

Compartment wall with metal support structure and cladding on both sides

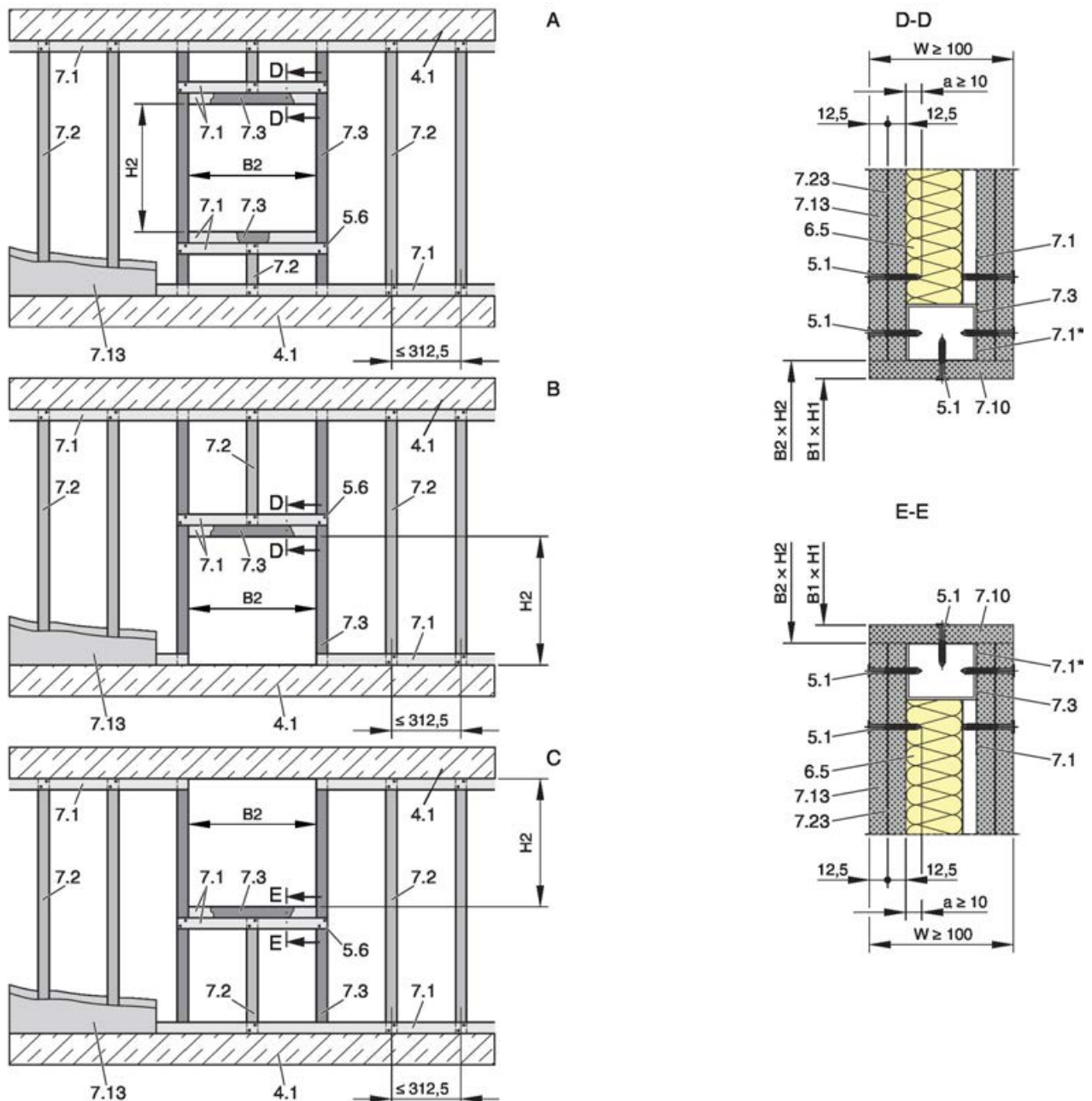

Fig. 29: Compartment wall with metal support structure and cladding on both sides

| | | | |
|-----|--|---------|--|
| A | Lightweight partition wall with metal support structure or steel support structure / compartment wall / safety partition wall | 7.2 | CW section |
| | | 7.3 | UA section |
| B | Lightweight partition wall with metal support structure or steel support structure / compartment wall / safety partition wall, installation near the floor | 7.10 | Trim panels according to installation details |
| | | 7.13 | Cladding |
| | | 7.23 | Sheet steel insert (if any, depends on wall manufacturer) |
| C | Lightweight partition wall with metal support structure or steel support structure / compartment wall / safety partition wall, installation near the ceiling | B1 × H1 | Installation opening |
| | | B2 × H2 | Opening in the metal support structure (without trim panels: B2 = B1, H2 = H1) |
| | | * | Closed side of metal section must face the installation opening |
| 4.1 | Solid ceiling slab / solid floor | # | Arrangement may vary |
| 5.1 | Dry wall screw | | |
| 5.6 | Screw or steel rivet | | |
| 6.5 | Mineral wool (depending on wall construction) | | |
| 7.1 | UW section | | |

7.1a UW section, either cut in and bent or cut off

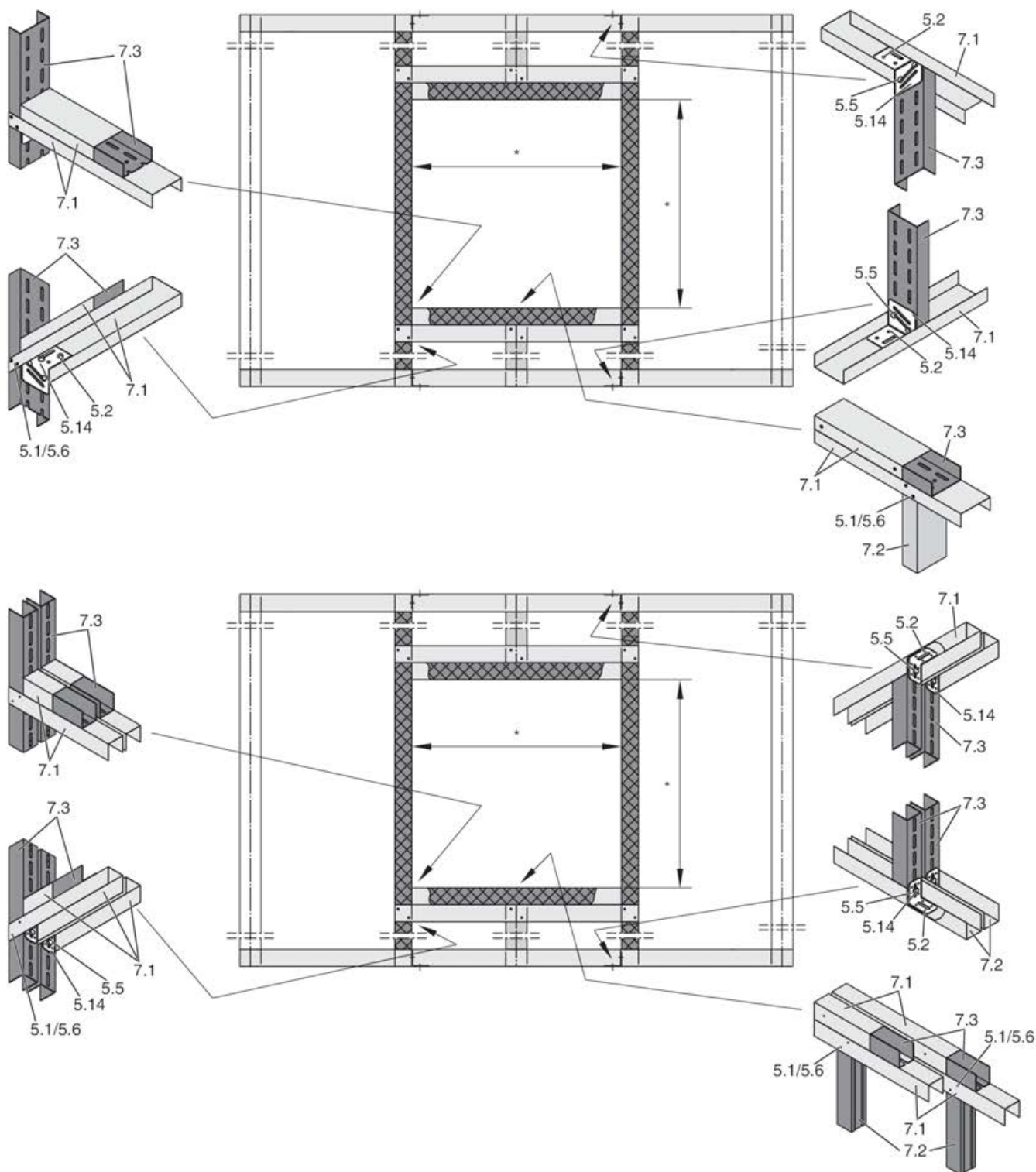
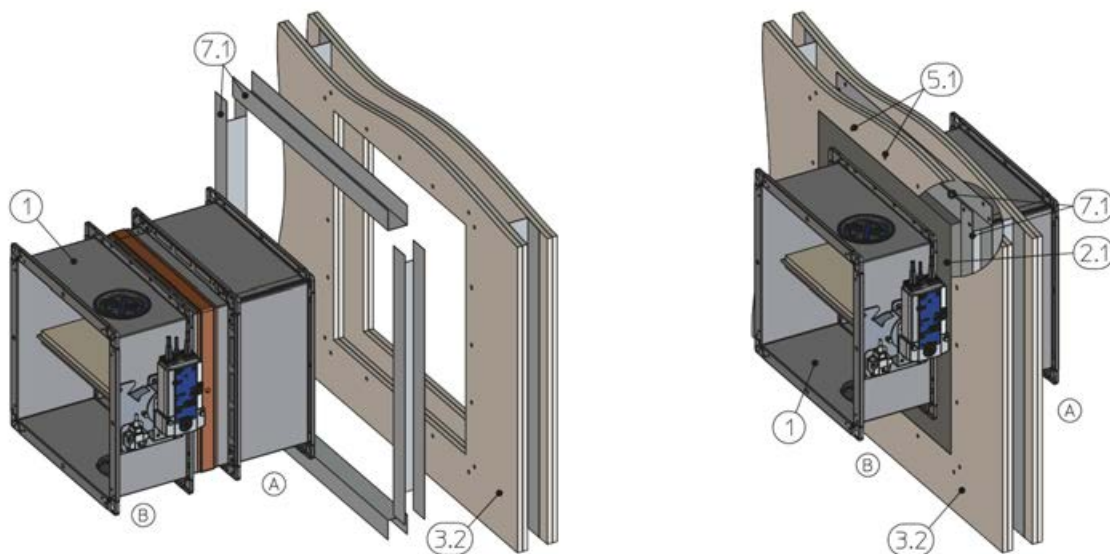

Fig. 30: Metal support structure for a compartment wall, single stud system and double stud system

| | | | |
|------|---|-----|--|
| 5.1 | Dry wall screw | 7.1 | UW section |
| 5.2 | Hexagon head screw M6 | 7.2 | CW section |
| 5.5 | Carriage bolt, L ≤ 50 mm, with washer and nut | 7.3 | UA section |
| 5.6 | Steel rivet | * | Installation opening according to installation details |
| 5.14 | Angle bracket | | |

Installation at a later stage

GR3478229, A

Fig. 31: Installation into a lightweight partition wall at a later stage, for clear installation openings of ≤ 475 mm between two regular studs, illustration shows mortar-based installation (applies also to dry mortarless installation)

- | | | | |
|-----|---|-----|---|
| 1 | FK2-EU | 5.1 | Dry wall screw, screw spacing ≤ 100 mm |
| 2.1 | Mortar | 7.1 | UW sections, cut to size (by others), overlapping |
| 3.2 | Lightweight partition wall with metal support structure, cladding on both sides | | |

Additional requirements: lightweight partition walls and compartment walls with metal support structure

- Lightweight partition wall or compartment wall, ↗ on page 40
- The structural safety of the wall must be ensured (by others). Compensation measures, especially with regard to large installation openings (such as for multiple installation), must be determined on a case to case basis (by others).

4.5.2 Dry mortarless installation with installation kit ES

Dry mortarless installation into a lightweight partition wall, with installation kit ES

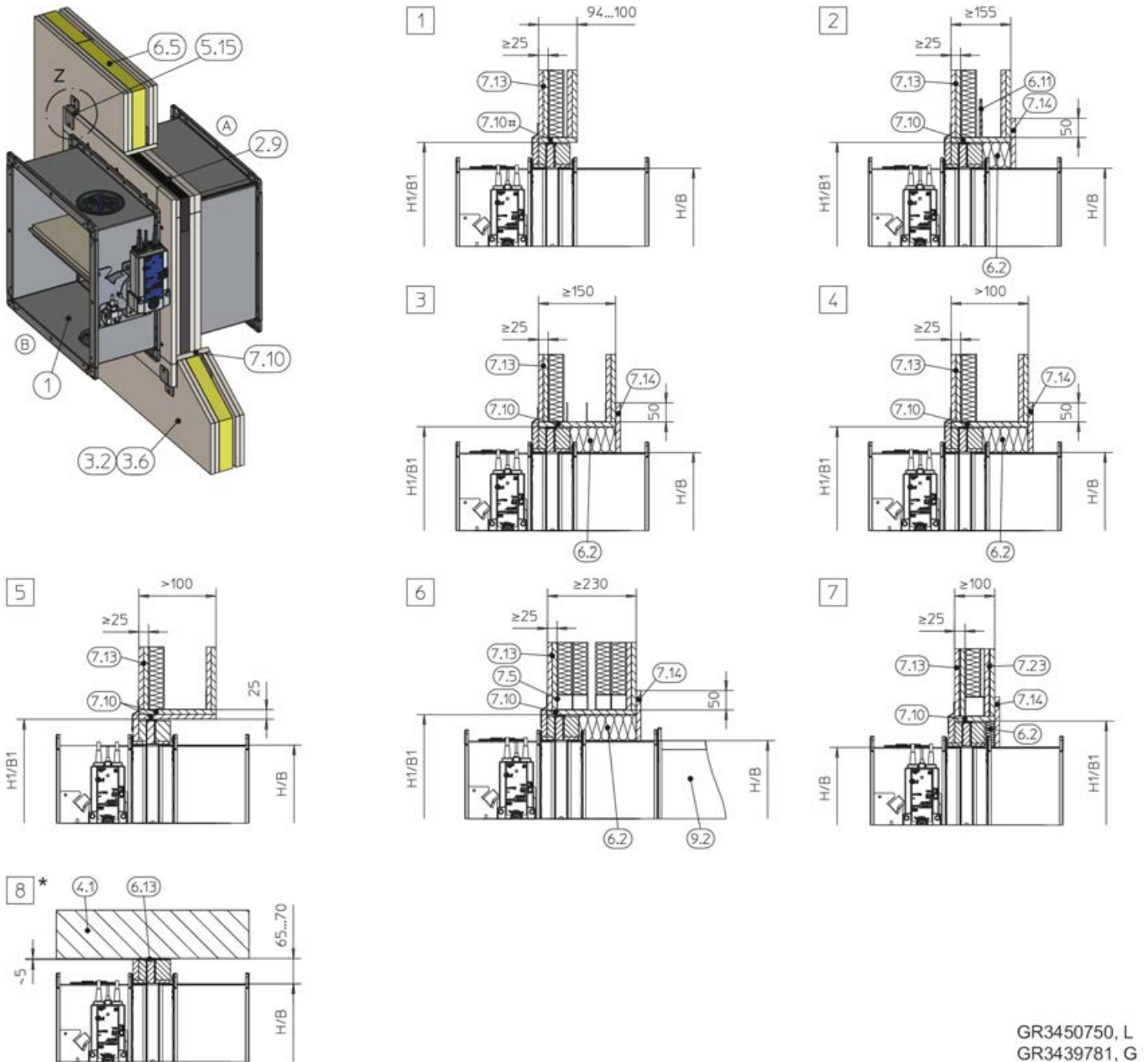

GR3450750, L
GR3439781, G

Fig. 32: Dry mortarless installation into a lightweight partition wall, with installation kit ES

| | | | |
|------|--|---------------------|--|
| 1 | FK2-EU | 7.10 | Trim panels |
| 2.9 | Installation kit ES | 7.10# | Optional trim panels |
| 3.2 | Lightweight partition wall with metal support structure, cladding on both sides | 7.13 | Cladding |
| 3.6 | Compartment wall or safety partition wall with metal support structure, cladding on both sides | 7.14 | Reinforcing board of the same material as the wall |
| 4.1 | Solid ceiling slab / solid floor | 7.23 | Sheet steel insert depending on wall manufacturer |
| 5.15 | Bracket | 9.2 | Extension piece or duct |
| 6.2 | Mineral wool, $\geq 1000\text{ }^\circ\text{C}$, $\geq 80\text{ kg/m}^3$ | * | Installation near the floor as in 8 |
| 6.5 | Mineral wool (depending on wall construction) | H1/B1 | Installation opening, see table 47 |
| 6.11 | Insulating strip (depending on wall construction) | Z | For fixing, see Fig. 17 to Fig. 19 |
| 6.13 | Mineral wool strips A1, filler as an alternative (if required to even out an uneven wall) | 1 – 8 | up to EI 120 S: B × H > 800 × 400 – 1500 × 800 mm |
| 7.5 | Steel support structure (box section) | | Up to EI 90 S: B × H = 200 × 100 – 1500 × 800 mm |

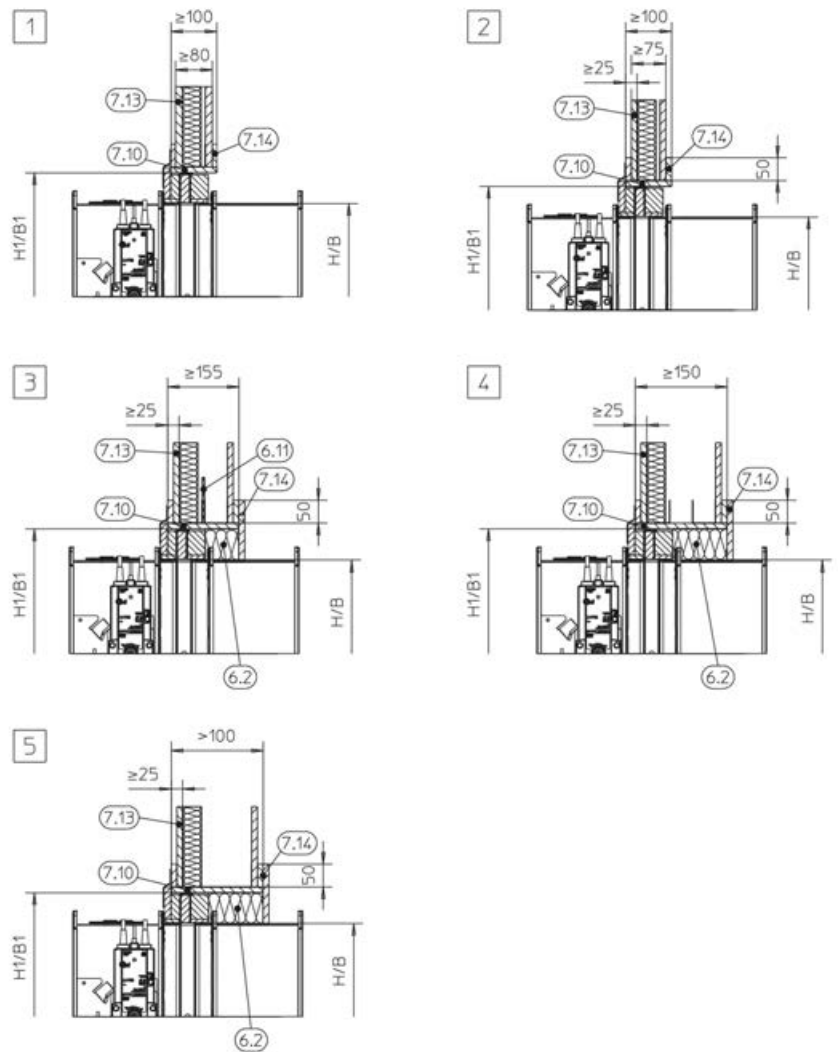
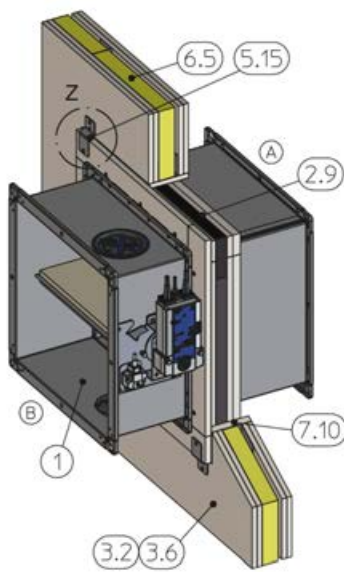

GR3450750, L

Fig. 33: Dry mortarless installation into a lightweight partition wall, with installation kit ES

| | | | |
|------|--|-------|--|
| 1 | FK2-EU | 7.10 | Trim panels |
| 2.9 | Installation kit ES | 7.13 | Cladding |
| 3.2 | Lightweight partition wall with metal support structure, cladding on both sides | 7.14 | Reinforcing board of the same material as the wall |
| 3.6 | Compartment wall or safety partition wall with metal support structure, cladding on both sides | H1/B1 | Installation opening, see table 47 |
| 5.15 | Bracket | Z | For fixing, see Fig. 17 to Fig. 19 |
| 6.2 | Mineral wool, $\geq 1000\text{ }^{\circ}\text{C}$, $\geq 80\text{ kg/m}^3$ (required for wall thicknesses $> 100\text{ mm}$) | 1 | up to EI 60 |
| 6.5 | Mineral wool (depending on wall construction) | 2 – 5 | EI 30 S |
| 6.11 | Insulating strip (depending on wall construction) | | |

Dry mortarless installation into a lightweight partition wall, below a flexible ceiling joint

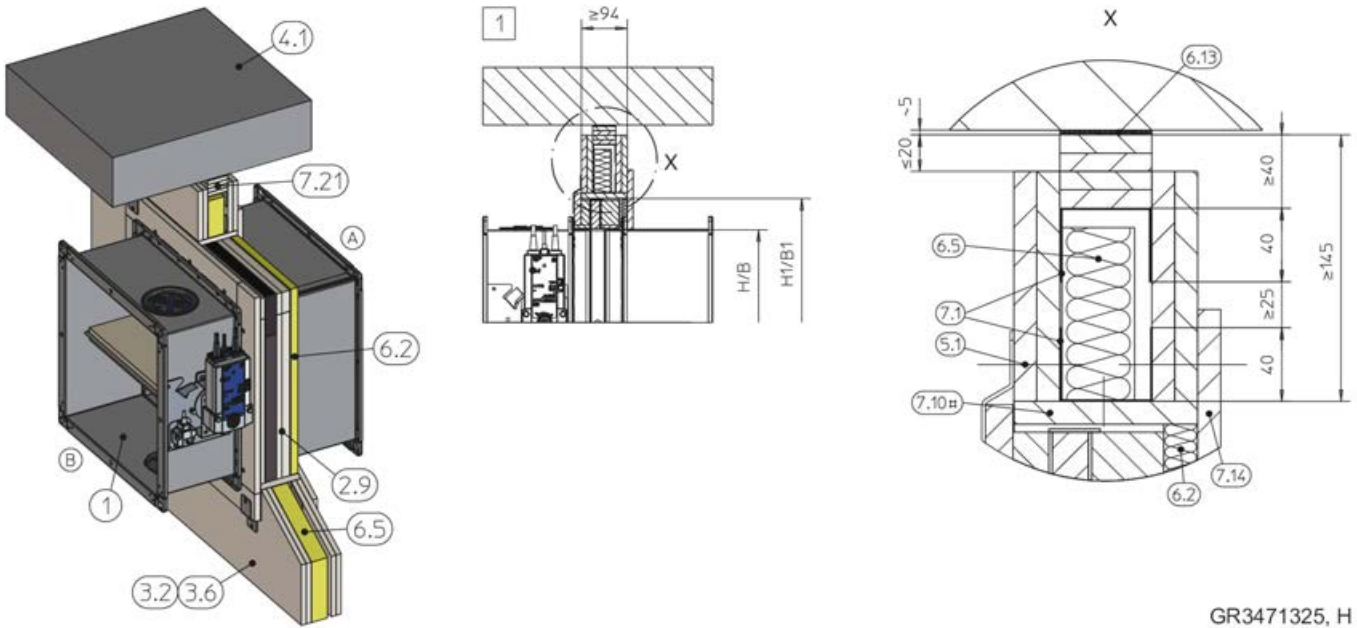

GR3471325, H

Fig. 34: Dry mortarless installation into a lightweight partition wall, below a flexible ceiling joint

| | | | |
|------|--|-------|---|
| 1 | FK2-EU | 6.13 | Mineral wool strips A1, filler as an alternative (if required to even out an uneven wall) |
| 2.9 | Installation kit ES | 7.1 | UW section |
| 3.2 | Lightweight partition wall with metal support structure, cladding on both sides | 7.10# | Optional trim panels |
| 3.6 | Compartment wall or safety partition wall with metal support structure, cladding on both sides | 7.14 | Reinforcing board of the same material (required if $W > 100$ mm) |
| 4.1 | Solid ceiling slab | 7.21 | Ceiling joint strips (e.g. $4 \times \geq 10$ mm) |
| 5.1 | Dry wall screw | H1/B1 | Installation opening, see table 47 |
| 5.15 | Bracket | Z | For fixing, see Fig. 17 to Fig. 19 |
| 6.2 | Mineral wool, ≥ 1000 °C, ≥ 80 kg/m ³ | 1 | up to EI 120 S: $B \times H > 800 \times 400 - 1500 \times 800$ mm |
| 6.5 | Mineral wool (depending on wall construction) | | Up to EI 90 S: $B \times H = 200 \times 100 - 1500 \times 800$ mm |

Additional requirements: dry mortarless installation with installation kit ES in lightweight partition walls

- Lightweight partition wall, 47 on page 40
- Casing length $L = 500$ mm
- Distance between the fire damper and adjacent structural elements $\geq 80 / 120$ mm (depending on the position of the brackets)
- 65 – 70 mm distance between the fire damper with a shortened installation kit and load-bearing structural elements, see Fig. 32 / Fig. 33 , detail 6
- ≥ 200 mm distance between two fire dampers in separate installation openings
- Ensure accessibility from the rear.
- For wall thicknesses > 100 mm, 2-layer trim panels (2-layer trim panels on three sides for installations near the ceiling) can be used as an alternative to the rear closure from 6.2 and 7.14.

1. ▶ Mount the installation kit onto the fire damper.

2. ▶ Position the fire damper in the centre of the installation opening and fix it with brackets and dry wall screws to the metal frame, see Fig. 17 to Fig. 19 .

4.5.3 Dry mortarless installation with fire batt

Dry mortarless installation into a lightweight partition wall, with a fire batt

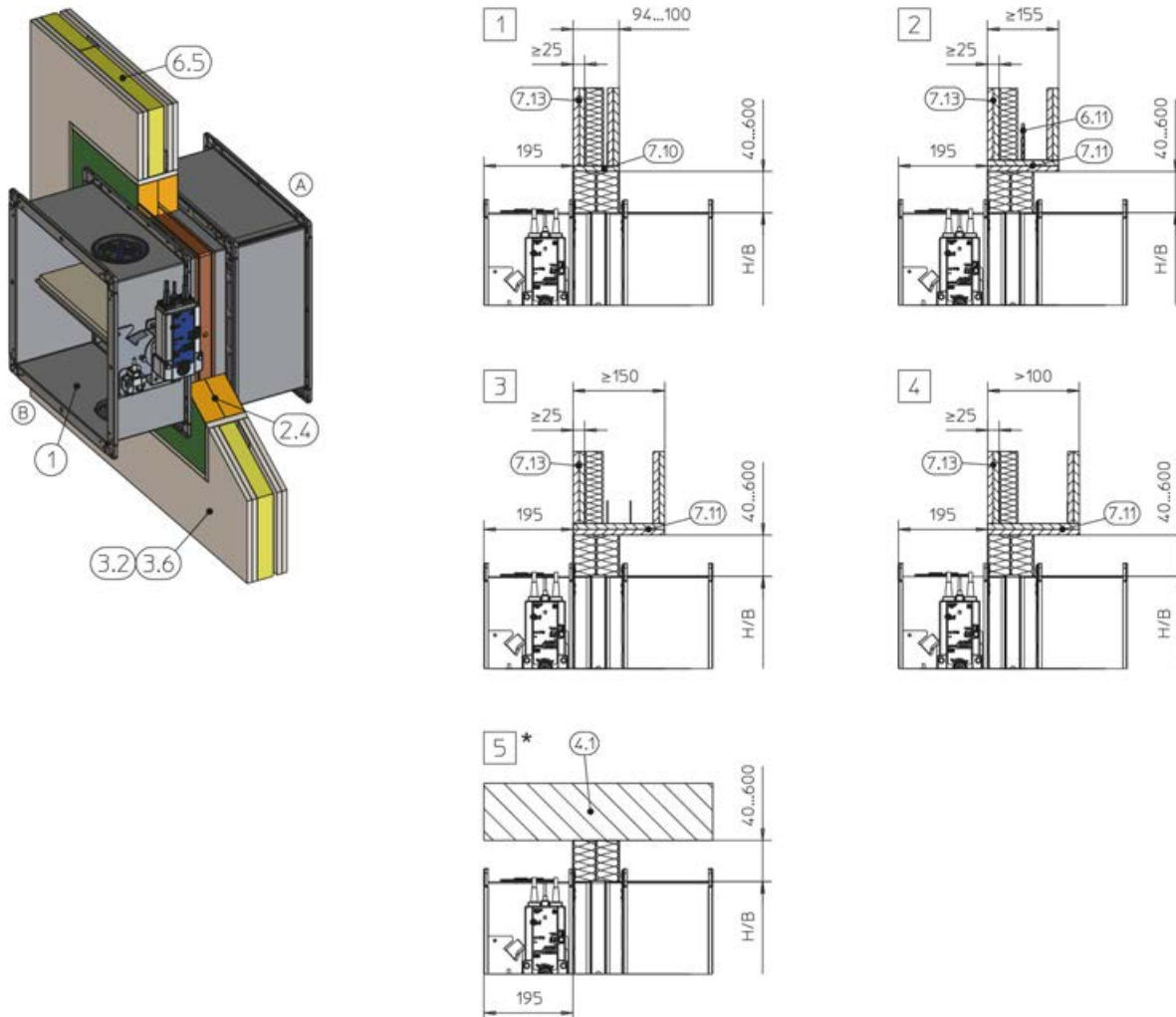

GR3469131, M

Fig. 35: Dry mortarless installation into a lightweight partition wall, with a fire batt

| | | | |
|------|--|-------|---|
| 1 | FK2-EU | 7.10 | Trim panels, up to $W \leq 100$ mm (optional) |
| 2.4 | Coated board system | 7.11 | Trim panels, double layer |
| 3.2 | Lightweight partition wall with metal support structure, cladding on both sides | 7.13 | Cladding |
| 3.6 | Compartment wall or safety partition wall with metal support structure, cladding on both sides | * | Installation near the floor as in [5] |
| 4.1 | Solid ceiling slab / solid floor | [1] – | up to EI 120 S: |
| 6.5 | Mineral wool (depending on wall construction) | [4] | $B \times H = 200 \times 100 - 800 \times 400$ mm (horizontal installation position) |
| 6.11 | Insulating strip (depending on wall construction) | [5] | Up to EI 90 S: $B \times H = 200 \times 100 - 1500 \times 800$ mm EI 30 to EI 120 S |

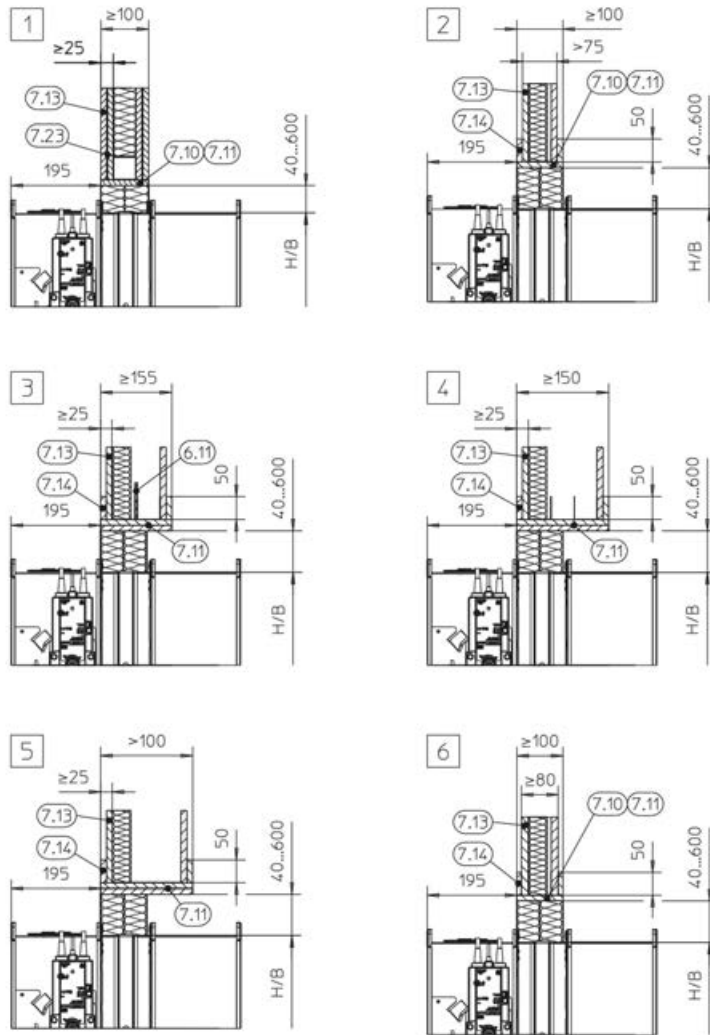
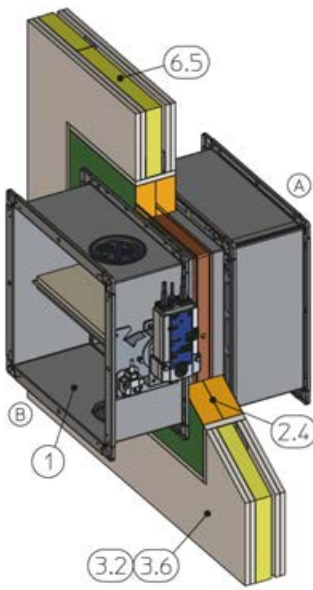

GR3469131, M

Fig. 36: Dry mortarless installation into a lightweight partition wall, with a fire batt

| | | | |
|------|--|------------|--|
| 1 | FK2-EU | 7.13 | Cladding |
| 2.4 | Coated board system | 7.14 | Reinforcing board of the same material as the wall |
| 3.2 | Lightweight partition wall with metal support structure, cladding on both sides | 7.23 | Sheet steel insert depending on wall manufacturer |
| 3.6 | Compartment wall or safety partition wall with metal support structure, cladding on both sides | 1 | up to EI 120 S: B × H = 200 × 100 – 800 × 400 mm (horizontal installation position) |
| 6.5 | Mineral wool (depending on wall construction) | | Up to EI 90 S: B × H = 200 × 100 – 1500 × 800 mm |
| 6.11 | Insulating strip (depending on wall construction) | 2 – | EI 30 S |
| 7.10 | Trim panels, up to W ≤ 100 mm (optional) | 5 | |
| 7.11 | Trim panels, double layer | 6 | Up to EI 60 S |

Dry mortarless installation with fire batt, flange to flange

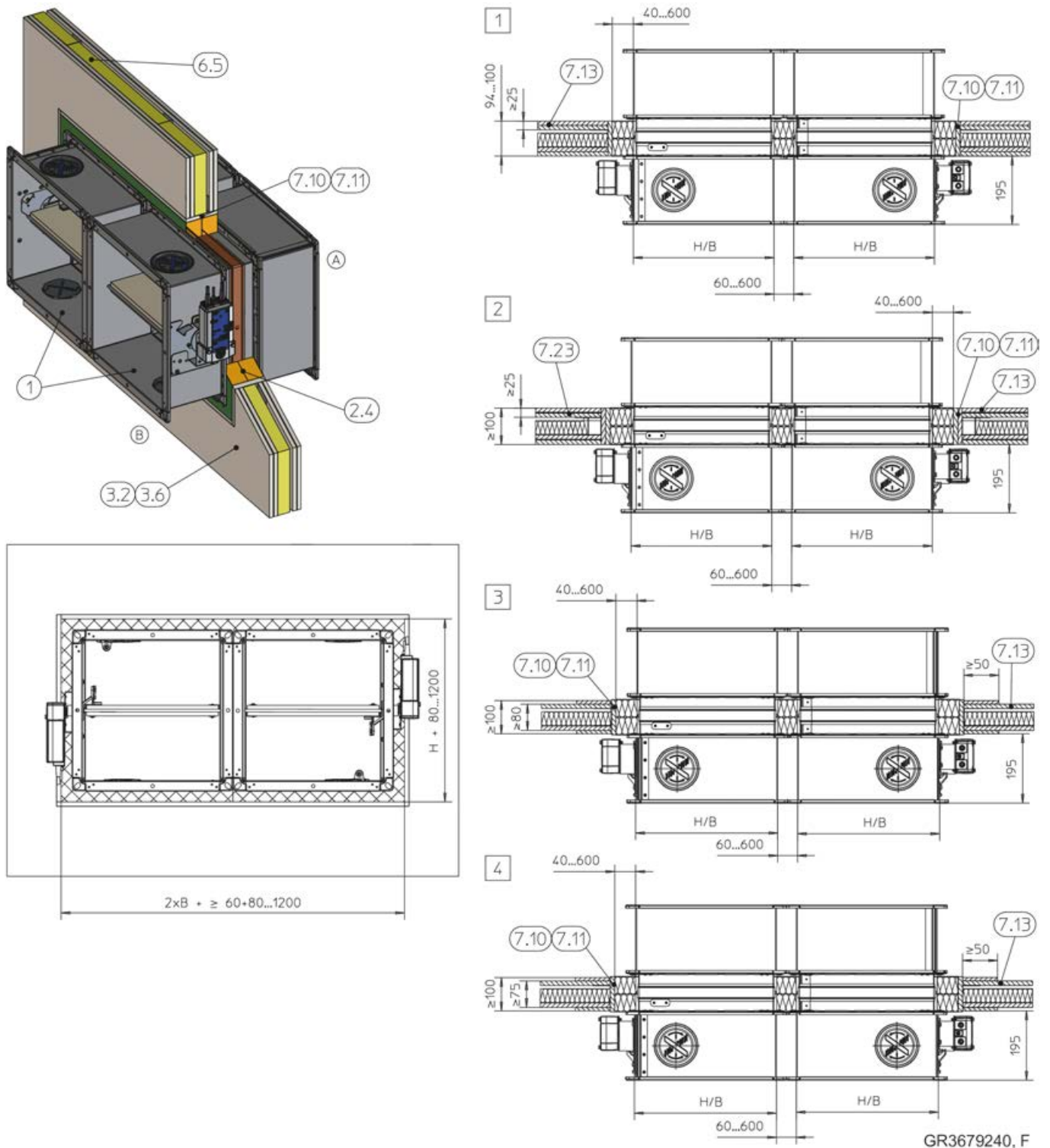

GR3679240, F

Fig. 37: Dry mortarless installation into a lightweight partition wall, with a fire batt, flange to flange, illustration shows side by side installation (applies also to installation of dampers on top of each other)

- | | | | |
|-----|---|------------|---|
| 1 | FK2-EU | 7.11 | Trim panels, double layer |
| 2.4 | Coated board system | 7.13 | Cladding |
| 3.2 | Lightweight partition wall with metal support structure, cladding on both sides | 7.23 | Sheet steel insert depending on wall manufacturer |
| 3.6 | Compartment wall with metal support structure, cladding on both sides | 1 2 | Up to EI 90 S |
| 6.5 | Mineral wool (depending on wall construction) | 3 | Up to EI 60 S |
| | | 4 | EI 30 S |

Lightweight partition walls > Dry mortarless installation with fire batt

7.10 Trim panels, up to $W \leq 100$ mm (optional)

Dry mortarless installation with fire batt, multiple installation, flange to flange

Additional requirements: dry mortarless installation into lightweight partition walls, with fire batt

- Lightweight partition wall, ↪ *on page 40*
- Casing length $L = 305$ or 500 mm
- Fire batt systems, installation details, distances / dimensions, ↪ *on page 38*
- Suspension and fixing, ↪ *Chapter 4.6 'Fixing the fire damper' on page 59* ↪ *4.6.3 'Fixing the damper when a fire batt is used' on page 61*

4.6 Fixing the fire damper

4.6.1 General

For installation remote from walls and ceilings and installation with fire batt, the fire dampers must be suspended with steel threaded rods (M10 – M12).

The rods have to be fixed to the ceiling slab; the required fire resistance must not be compromised. Use only fire-rated steel anchors with suitability certificate. Instead of anchors, you can use threaded rods and secure them using nuts and washers. Secure the threaded rods above the ceiling using steel nuts and washers. Threaded rods up to 1.50 m long do not require any insulation; longer rods do require insulation (according to Promat® work sheet 478, for example). Load the suspension system only with the weight of the fire damper, ducting must be suspended separately.

Weight [kg]: ↪ Chapter 2.2 'FK2-EU with fusible link' on page 10 ↪ Chapter 2.3 'FK2-EU with spring return actuator' on page 13 ↪ Chapter 2.4 'FK2-EU with spring return actuator and duct smoke detector' on page 20 ↪ Chapter 2.5 'FK2-EU with fusible link and cover grille as air transfer unit' on page 21 ↪ Chapter 2.6 'FK2-EU with spring return actuator and duct smoke detector as air transfer damper' on page 22 .

In addition to the fixing systems described in this manual, you may also use fixing systems that have been approved by accredited testing institutes. This applies in particular to the fire damper installation near a wall or in a corner (when angle sections or mounting plates are used).

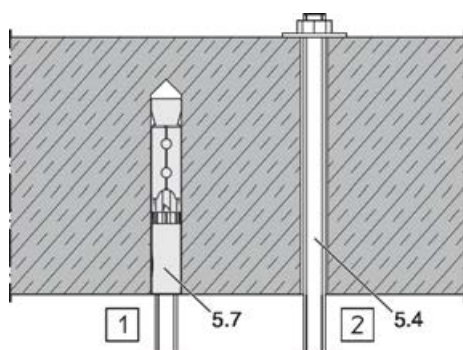

Fig. 38: Fixing to the ceiling slab

5.4 Threaded rod

5.7 Fire-rated anchor (with suitability certificate)

- 1 Fixing with wallplugs with suitability certificate for fire safety engineering
- 2 Fixing with threaded rod and push through installation

4.6.2 Suspending fire dampers installed remote from solid walls and ceiling slabs

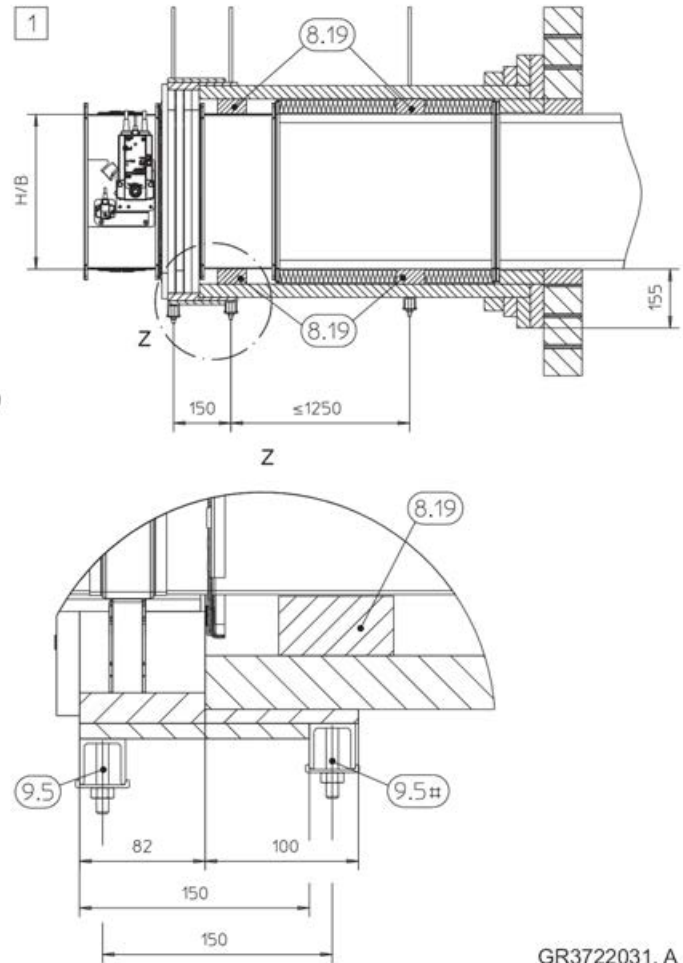
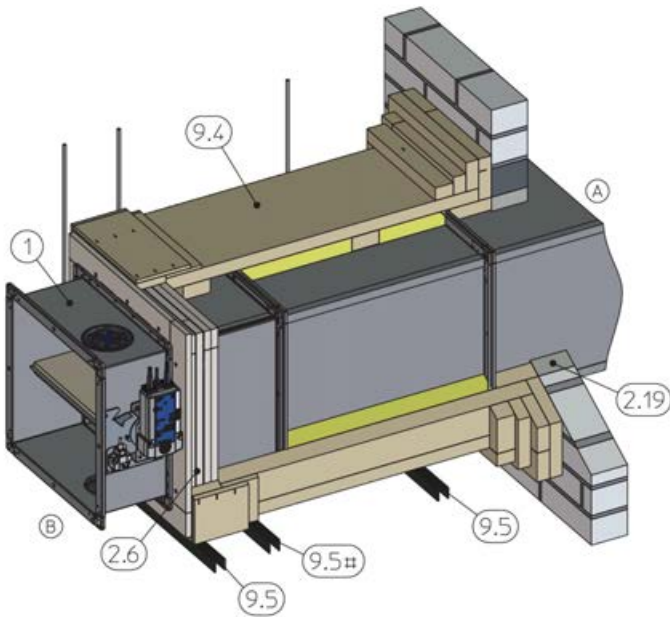

GR3722031, A

Fig. 39: Dry mortarless installation with installation kit WE

- | | |
|---|--|
| <p>1 FK2-EU</p> <p>2.6 Installation kit WE,</p> <p>2.19 Joint filler (suitable Promat® filler, Promat® ready-to-use filler or mineral wool, $\geq 1000\text{ }^{\circ}\text{C}$, $\geq 80\text{ kg/m}^3$ or mortar according to the installation and operating manual)</p> <p>8.19 PROMATECT® LS firestop board, $d = 35\text{ mm}$</p> <p>9.4 Sheet steel duct with fire-rated cladding and suspension system according to Promat® manual, construction 478, latest edition</p> <p>9.5 Suspension system (by others) consisting of:</p> <p>a Threaded rod</p> <p>M10: $B \times H \leq 800 \times 200\text{ mm}$</p> | <p>b Hilti® mounting rail MQ 41 \times 3 mm or equivalent</p> <p>c Hilti® drilled plate MQZ L13 or equivalent</p> <p>Hexagon nut with washer</p> <p># Damper sizes $> 1000 \times 600\text{ mm}$ require two suspension points underneath the damper, at a distance of 150 mm from each other</p> <p>Up to EI 90 S (horizontal installation position)</p> |
|---|--|

4.6.3 Fixing the damper when a fire batt is used

Horizontal duct

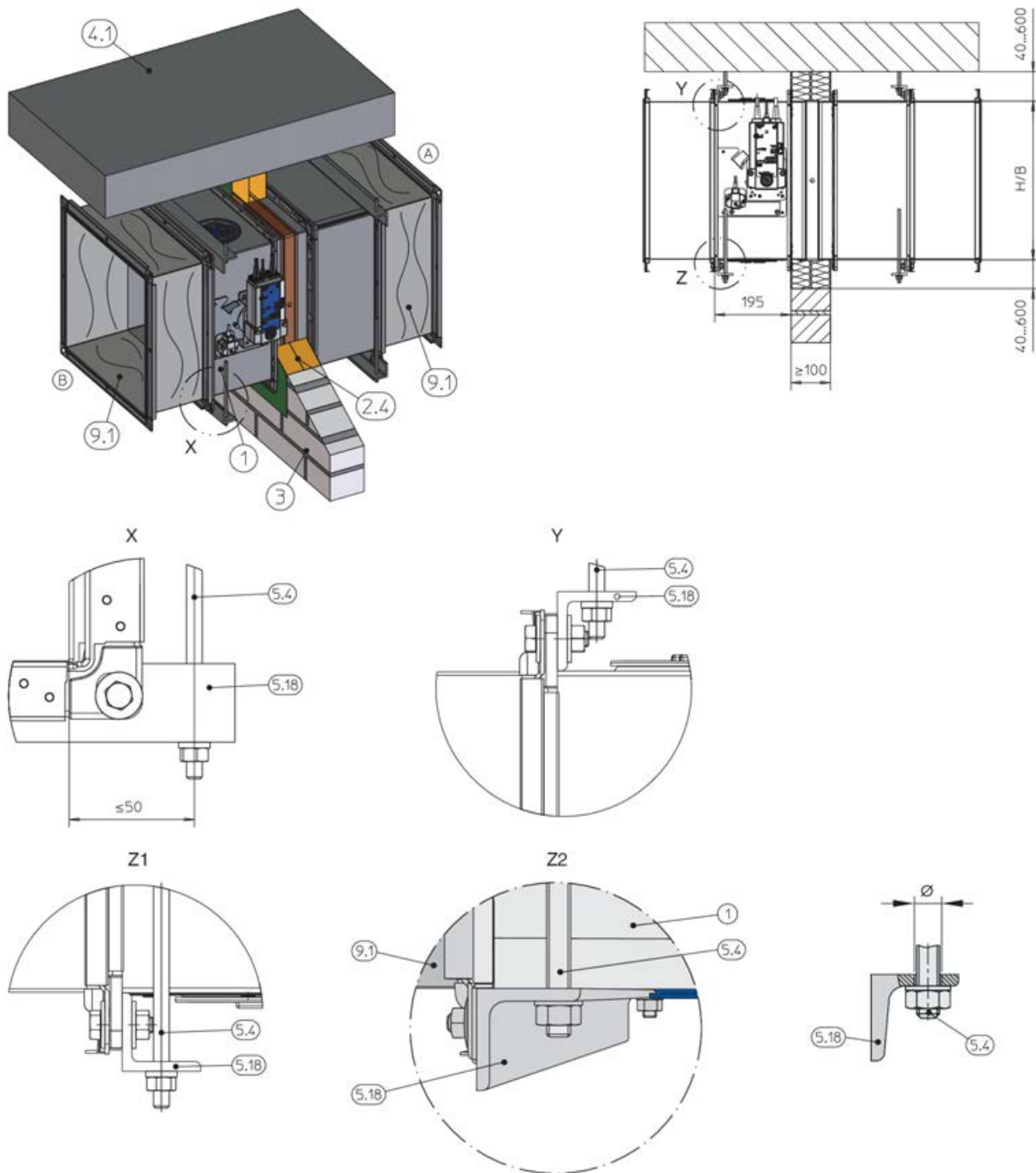

GR3722033, A

Fig. 40: Fixing of FK2-EU, wall installation with a fire batt

- | | | | |
|-----|--------------------------------------|------|---|
| 1 | FK2-EU | 5.18 | Steel angle section to EN 10056-1, L ≥ 40 mm × 40 mm × 5 mm, galvanised or painted, or equivalent |
| 2.4 | Coated board system | 9.1 | Flexible connector (recommended) |
| 3 | Wall, solid wall shown | Z1 | Suspension from EI 90 S |
| 4.1 | Solid ceiling slab | Z2 | Suspension up to EI 60 S |
| 5.4 | Threaded rod M12 with washer and nut | | |

Note: Each fire damper has to be suspended both on the operating side and on the installation side. The suspension has to be fixed either to the top **or** to the bottom of the flange.

Fixing the fire damper > Fixing the damper when a fire batt is used

Vertical duct

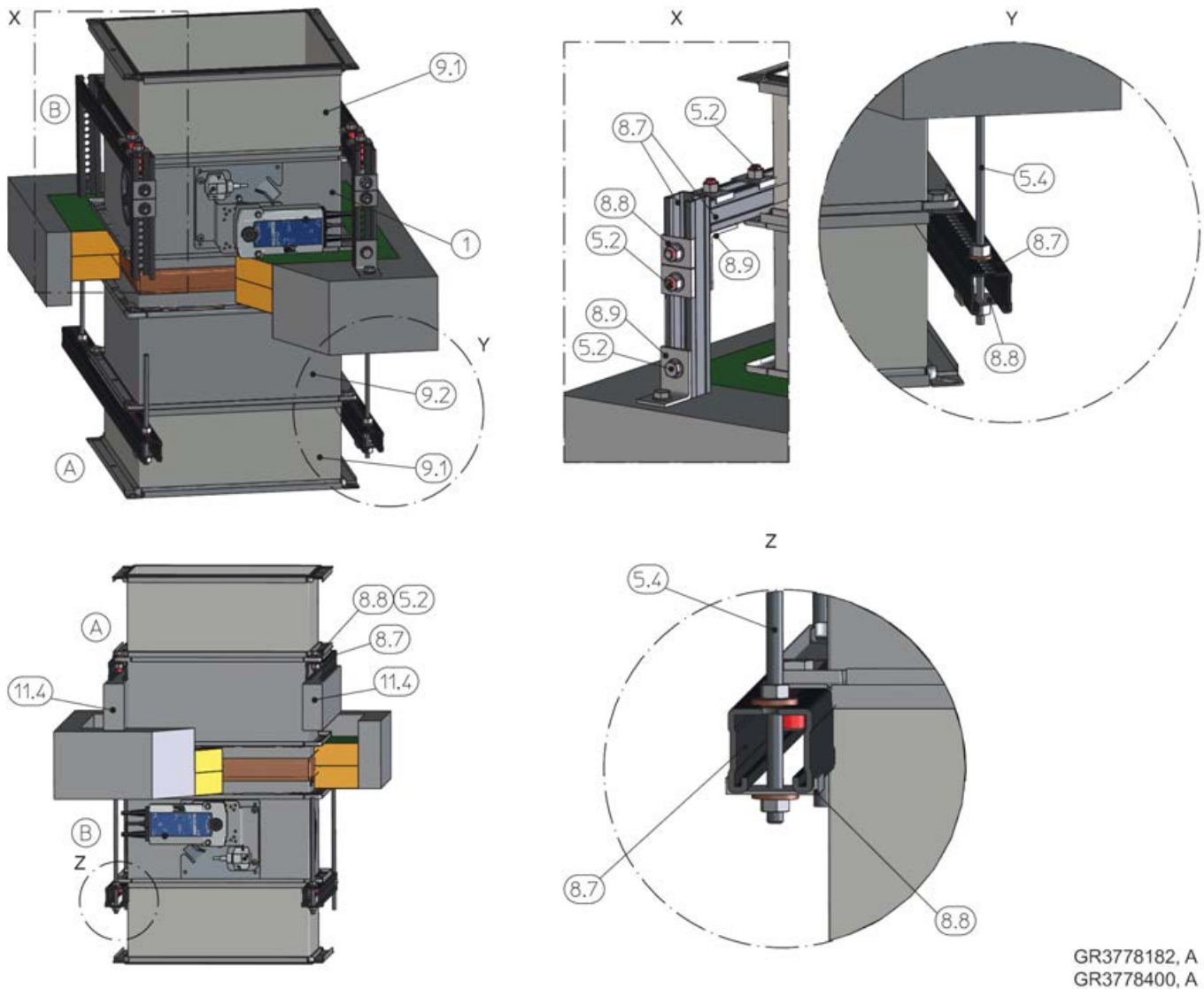

GR3778182, A
GR3778400, A

Fig. 41: Suspension in fire batt, FK2-EU upright or suspended

| | | | |
|-----|--|------|---|
| 1 | FK2-EU | 8.9 | System bracket, Varifix ANSHWNKL-PRFL36-90GRAD or Müpro mounting bracket 90°, galvanised, or equivalent |
| 5.2 | Screw M10 × 70 mm, with washer and nut | 9.1 | Flexible connector (recommended) |
| 5.4 | Threaded rod M12 with washer and nut | 9.2 | Extension piece |
| 8.7 | Mounting rail Würth Varifix 36 × 36 × 2.5 or Müpro MPC 38/40 or equivalent | 11.4 | Underlay material, non-combustible |
| 8.8 | Fixing bracket, Varifix or Müpro MPC or equivalent | | |

Note:

- Installation of the fire damper in vertical ducts with a fire batt from EI 90 S requires the fire damper to be fixed both above and below the ceiling slab, see Fig. 41 . The fire damper should be suspended along the shorter casing sides if at all possible.
- When installing adjacent to a solid wall, fixing the steel bracket to the solid wall is also permissible. The equivalence of the fastening must be ensured on site.

 **DANGER!****Danger of falling off! Do not step onto the fire batt!**

The fire batt cannot carry any loads. Adequate means, e.g. a permanent barrier, must be installed to prevent people from stepping onto the fire batt.

5 Electrical connection

5.1 General safety notes

⚠ DANGER!

Danger of electric shock! Do not touch any live components! Electrical equipment carries a dangerous electrical voltage.

- Only skilled qualified electricians are allowed to work on the electrical system.
- Switch off the power supply before working on any electrical equipment.

The connecting cables are sized by others depending on the supply voltage (230 V or 24 V), the cable length and the power consumption and number of actuators.

5.2 Limit switches (fire dampers with fusible link)

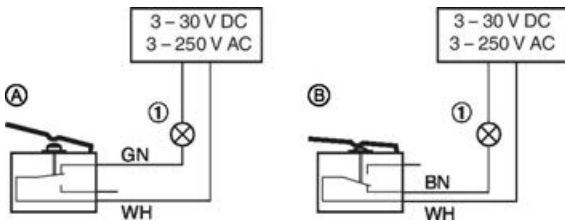

Fig. 42: Wiring of limit switches, example

- 1 Indicator light or relay, to be provided by others
- A Type of connection normally closed
B Type of connection normally open
- The limit switches must be connected according to the wiring example Fig. 42
 - Indicator lights or relays may be connected as long as the performance specifications are taken into consideration.
 - Connection boxes must be fixed to the adjoining structure (wall or ceiling slab). They must not be fixed to the fire damper.

| Type of connection | Limit switch | Damper blade | Electric circuit |
|--------------------|--------------|--|------------------|
| A | Not actuated | CLOSED or OPEN position <u>not</u> reached | Closed |
| B | actuated | CLOSED or OPEN position reached | Closed |

Note: For wiring explosion-proof limit switch, see "Supplementary operating manual for explosion-proof fire dampers Type FK2-EU".

5.3 Spring return actuator

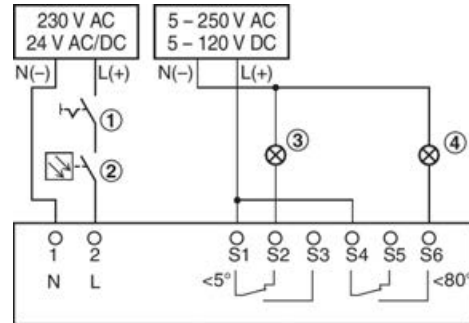

Fig. 43: Actuator connection, example

- 1 Switch for opening and closing, to be provided by others
- 2 Optional release mechanism, e.g. TROX duct smoke detector Type RM-O-3-D or RM-O-VS-D
- 3 Indicator light for CLOSED position, to be provided by others
- 4 Indicator light for OPEN position, to be provided by others

- The fire damper may be equipped with a spring return actuator for a supply voltage of 230 V AC or 24 V AC/DC. See the performance data on the actuator rating plate.
- The spring return actuator must be connected according to the wiring example shown. Several actuators can be connected in parallel as long as the performance specifications are taken into consideration.
- Connection boxes must be fixed to the adjoining structure (wall or ceiling slab). They must not be fixed to the fire damper.

Note: For wiring explosion-proof spring return actuator see "Supplementary operating manual for explosion-proof fire dampers Type FK2-EU".

Actuators with 24 V AC/DC

Safety transformers must be used. The connecting cables are fitted with plugs. This ensures quick and easy connection to the TROX AS-i bus system. For connection to the terminals, shorten the connecting cable.

5.4 Spring return actuator and duct smoke detector RM-O-3-D

Note: For connection examples and further details see the RM-O-3-D operating and installation manual

6 Functional test

6.1 General

General

During operation at normal temperatures, the damper blade is open. A functional test involves closing the damper blade and opening it again.

 **CAUTION!**

Danger of injury when reaching into the fire damper while the damper blade is moving. Do not reach into the fire damper while actuating the release mechanism.

6.2 Functional test with automatic control unit

Functional test with automatic control unit

The function of fire dampers with a spring return actuator can also be tested with an automatic control unit. The control unit should have the following functions:

- Opening and closing fire dampers in regular intervals (intervals to be set by the system owner)
- Monitoring of the actuator running times
- Issuing an alarm when the running times are exceeded and when fire dampers close
- Recording the test results

TROXNETCOM systems such as TNC-EASYCONTROL or AS-interface meet all these requirements. For more information see www.troxtechnik.com.

TROXNETCOM systems allow for automatic functional tests; they do not replace maintenance and cleaning, which have to be carried out in regular intervals or depending on the condition of the product. The documentation of test results makes trends visible, e.g. the run time of actuators. They may also indicate the need for additional measures which help to maintain the system's function, e.g. removing heavy contamination (dust in extract air systems).

6.3 Fire damper with fusible link

6.3.1 Fusible link – size 1

damper blade position indicator

The position of the damper blade (1.2) is indicated by the position of the handle (1.6).

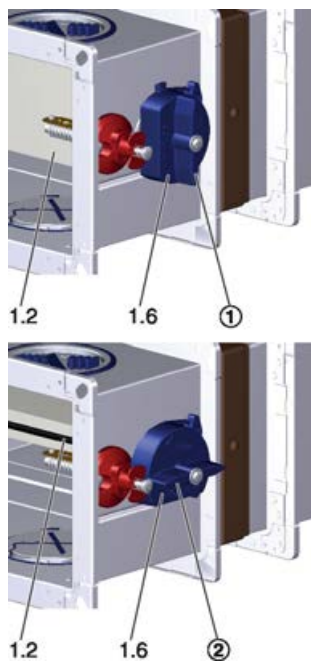

Fig. 44: damper blade position indicator

1. ▶ Damper blade (1.2) is closed.
2. ▶ Damper blade (1.2) is open.

Close the damper blade

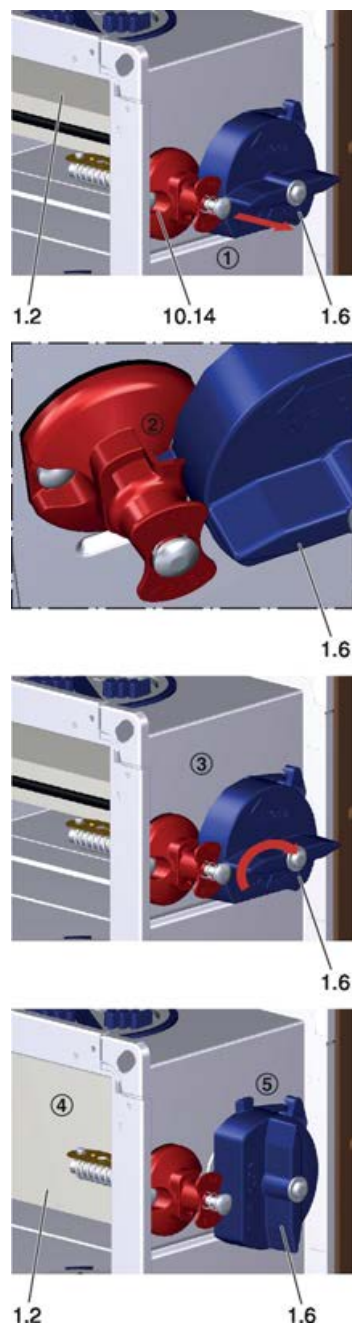

Fig. 45: Close the damper blade

Requirement

- Fire damper is open.
1. ▶ Pull the knob of the thermal release mechanism (10.14) forwards in the direction of the arrow to release
 2. ▶ the handle (1.6).
 3. ▶ The handle (1.6) swivels automatically in the direction of the arrow.
 4. ▶ The damper blade (1.2) is closed and
 5. ▶ the handle (1.6) shows that the damper blade (1.2) is closed.

Opening the damper blade

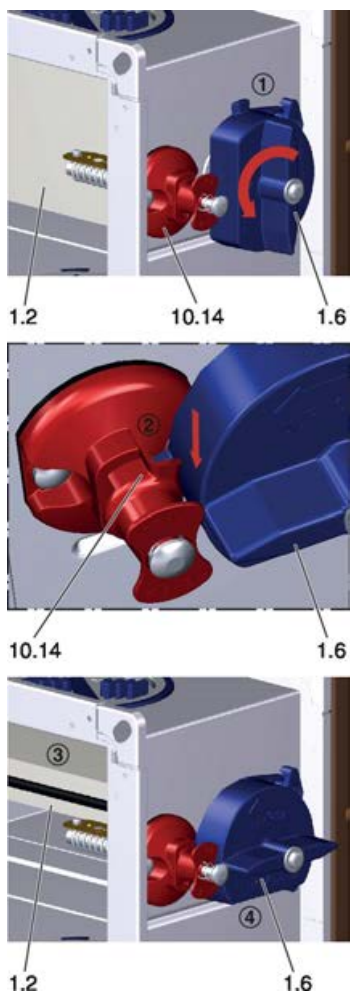

Fig. 46: Opening the damper blade

Requirement

- The damper blade is CLOSED.
- 1. ▶ Turn the handle (1.6) anti-clockwise (see arrow) until
- 2. ▶ the handle (1.6) locks into place (10.14).
- 3. ▶ The damper blade (1.2) is now open and
- 4. ▶ the handle (1.6) indicates that the damper blade (1.2) is open.

6.3.2 Fusible link – sizes 2 and 3 damper blade position indicator

The position of the damper blade (1.2) is indicated by the red arrow on the cover of the handle (1.6).

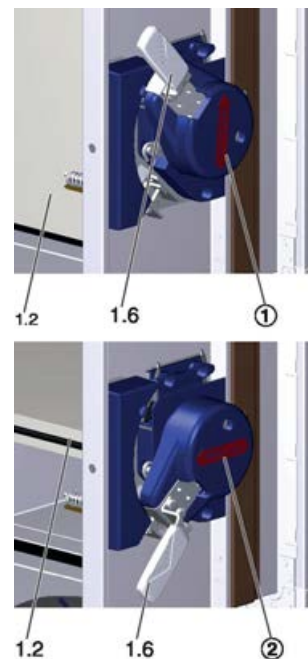

Fig. 47: damper blade position indicator

1. ▶ Damper blade (1.2) is closed.
2. ▶ Damper blade (1.2) is open.

Close the damper blade



1.2 10.16 ② 1.6

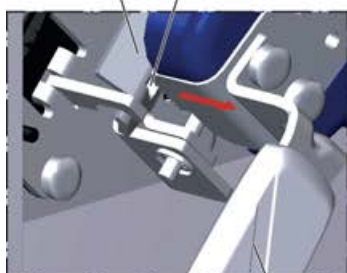

1.6

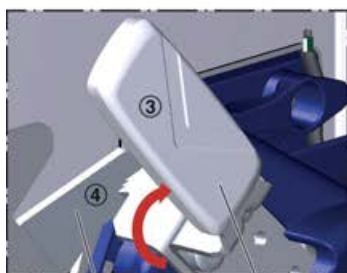

1.7

1.6



1.2

1.6

2. ▶ handle (1.6) no longer protrudes into the hole of the fusible link holder lever (10.16).
3. ▶ The handle (1.6) swivels automatically into the direction of the arrow (clockwise)
4. ▶ and locks into the CLOSED position on the interlock (1.7).
5. ▶ The damper blade (1.2) is now closed and
6. ▶ the red arrow on the handle (1.6) indicates that the damper blade (1.2) is closed.

Fig. 48: Close the damper blade

Requirement

- The damper blade is OPEN.
1. ▶ Lift the handle (1.6) in the direction of the arrow so that the

Opening the damper blade

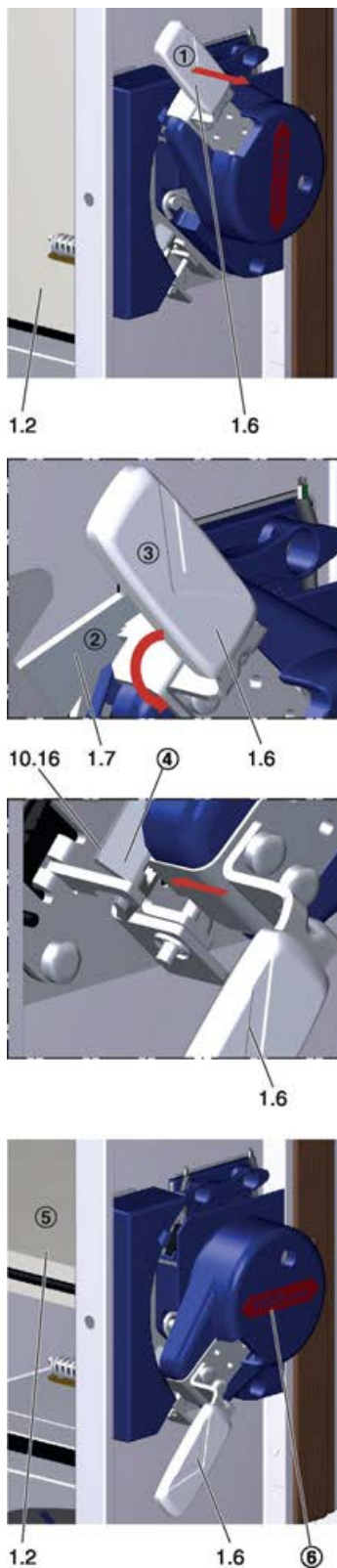

2. ▶ the handle (1.6) is no longer engaged with the interlock (1.7).
3. ▶ Turn the handle (1.6) in the direction of the arrow (anti-clockwise) without lifting it further.
4. ▶ The handle (1.6) locks into the OPEN position in the hole of the fusible link holder lever (10.16).
5. ▶ The damper blade (1.2) is now open and
6. ▶ the red arrow on the handle (1.6) indicates that the damper blade (1.2) is open.

Fig. 49: Opening the damper blade

Requirement

- The damper blade is CLOSED.
1. ▶ Lift the handle (1.6) in the direction of the arrow until

6.4 Fire damper with spring return actuator

6.4.1 Spring return actuator – BFL... / BFN...

Status indicator



Fig. 50: Thermoelectric release mechanism BAT

- 1 Push button for functional test
- 2 Indicator light

The indicator light (2) for the thermoelectric release mechanism is illuminated when all of the following conditions apply:

- Power is being supplied.
- The thermal fuses are intact.
- The push button is not being pushed.

damper blade position indicator

The position of the damper blade is indicated by the pointer on the actuator.



Fig. 51: damper blade position indicator

- 1 Damper blade is closed
- 2 Damper blade is open

Closing/opening the damper blade with spring return actuator



Fig. 52: Functional test (illustration shows FK2-EU with BFN actuator in OPEN position)

CAUTION!

Danger of injury when reaching into the fire damper while the damper blade is moving. Do not reach into the fire damper while actuating the release mechanism.

Requirement

- Power is being supplied
1. ▶ Push the toggle switch (1) and keep it pushed.
 - ⇒ This interrupts the power supply, and the damper blade closes.
 2. ▶ Check if the damper blade is CLOSED, check run time.
 3. ▶ Release the toggle switch (1).
 - ⇒ Power is supplied again, and the damper blade opens.
 4. ▶ Check if the damper blade is OPEN, check run time.

Opening the damper blade using the crank handle



Fig. 53: Functional test (without power supply)

! DANGER!

Danger due to malfunction of the fire damper.

If the damper blade has been opened by means of the crank handle (without power supply), it will no longer be triggered by a temperature increase, i.e. in the event of a fire. In other words, the damper blade will not close.

To re-establish its function, connect the power supply.

Requirement

- The damper blade is CLOSED
- 1. ▶ Insert the crank handle (1) into the opening for the spring winding mechanism.
- 2. ▶ Turn the crank handle in the direction of the arrow (2) to just short of the travel stop and hold it.
- 3. ▶ Set the interlock (3) to "Lock  closed"
 - ⇒ The damper blade remains in the OPEN position.
- 4. ▶ Remove the crank handle.

Close the fire damper



Fig. 54: Functional test (without power supply)

! CAUTION!

Danger of injury when reaching into the fire damper while the damper blade is moving. Do not reach into the fire damper while actuating the release mechanism.

Requirement

- The damper blade is OPEN
 - ▶ Set the interlock (3) to "Lock  opened"
 - ⇒ The damper blade is released and closes.

7 Commissioning

Before commissioning

Before commissioning, each fire damper must be inspected to determine and assess its actual condition.

The inspection work to be carried out is listed in the complete instructions, see installation and operating manual FK2-EU.

Operation

During normal operation the damper blade is open to enable air passage through the ventilation system.

If the temperature in the duct ($\geq 72\text{ °C}$ / $\geq 95\text{ °C}$ in warm air ventilation systems) or the ambient temperature ($\geq 72\text{ °C}$) rises in the event of a fire, the thermal release mechanism is triggered. This action closes the damper blade.



CLOSED fire dampers

Fire dampers which close while the ventilation system is running must be inspected before they are opened again in order to ensure their correct function.

8 Index

A

- Air transfer damper..... 6 , 22
- Air transfer unit..... 21

B

- Bearing..... 24

C

- Casing length..... 10 , 13 , 17 , 21
- Combined installation..... 25
- Combined penetration seal..... 6 , 25
- Commissioning..... 72
- Compartment walls with metal support structure and cladding on both sides..... 46
- Composite ceilings..... 25 , 42
- Copyright..... 3
- Correct use..... 6

D

- damper blade position indicator..... 66 , 67 , 70
- Defects liability..... 3
- Dimensions..... 10 , 13 , 17 , 20 , 21 , 22
- Dry mortarless installation..... 25
- Duct smoke detector..... 20 , 22 , 64

E

- Electrical connection..... 64
- Even number of holes..... 12
- Ex areas..... 6

F

- Fire batt..... 25 , 39
- Fire protection block bulkhead..... 6
- Flange holes..... 12
- Flexible ceiling joint..... 25
- Functional test..... 65

G

- Gypsum wallboard..... 25

H

- Half-timbered constructions..... 25 , 41
- Historical wooden beam ceilings..... 42
- Historic wooden beam ceilings..... 25
- Hollow concrete block ceilings..... 25 , 42
- Hollow core slabs..... 25 , 42
- Hotline..... 3

I

- Installation position..... 32
- Installation side..... 10 , 13 , 17 , 21
- Installation situations..... 25

L

- Lightweight ceilings..... 25 , 42
- Lightweight partition walls with metal support structure..... 40

- Lightweight partition walls with metal support structure and cladding on both sides..... 46

- Lightweight partition walls with timber support structure..... 41

- Limitation of liability..... 3

- Limit switch..... 10 , 64

M

- Metal stud walls..... 25

- Mortar-based installation..... 25

- Multiple installation..... 25

O

- Operating side..... 10 , 13 , 17 , 21

- Operation..... 72

P

- Packaging..... 24

- Partial mortaring..... 25

- Personnel..... 7

- Product sticker..... 9

R

- Ribbed ceilings..... 25 , 42

S

- Sandwich panel walls..... 25

- Service..... 3

- Shaft walls..... 25

- Shaft walls with metal support structure..... 41

- Shaft walls without metal support structure..... 41

- Side B..... 10 , 13 , 17 , 21

- Side H..... 10 , 13 , 17 , 21

- Sizes..... 10 , 21

- Solid ceiling slabs..... 25 , 42

- Solid walls..... 25 , 40 , 43

- Solid wood ceilings..... 25 , 42

- Solid wood walls..... 25 , 41

- Spring return actuator..... 14 , 15 , 18 , 19 , 64

- Supply package..... 24

- Suspension..... 59

- Symbols..... 4

T

- Technical data..... 8

- Technical Service..... 3

- Threaded rods..... 59

- Timber stud walls..... 25

- Transport..... 24

- Transport damage..... 24

U

- Uneven number of holes..... 12

- Upstream shutters for air transfer units..... 6

| | | | |
|-----------------------|----|---------------------------|-----------------------------|
| W | | Warranty claims..... | 3 |
| Wall attachment..... | 25 | Weights..... | 10 , 13 , 17 , 20 , 21 , 22 |
| Wall penetration..... | 25 | Wooden beam ceilings..... | 25 , 42 |

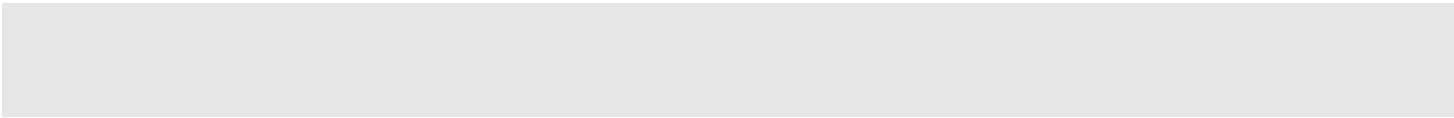

TROX[®] TECHNİK

The art of handling air

TROX GmbH
Heinrich-Trox-Platz
47504 Neukirchen-Vluyn, Ger-
many

Germany
Phone: +49 (0) 2845 2020
+49 (0) 2845 202-265
E-mail: trox-de@troxgroup.com
<http://www.troxtechnik.com>

© 2021