

# TCU-LON II Controller

**TROX<sup>®</sup> TECHNIK**

Gebrüder Trox GmbH

Telephone +49 (0) 28 45/2 02-0

Telefax +49 (0) 28 45/2 02-2 65

Heinrich-Trox-Platz

[www.troxtechnik.com](http://www.troxtechnik.com)

D-47504 Neukirchen-Vluyn

e-mail [trox@trox.de](mailto:trox@trox.de)

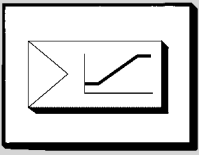

## Contents

<b>Subject</b>	<b>Page</b>
Applications _____	3
Functional Description _____	4
Fume Cupboard Control _____	5
Overview of Most Important Functions _____	6
Room-Volume Flow Control _____	7
Room Control Taking Account of Simultaneity _____	8
Operator Terminal _____	9
Room Pressure/Room Balance Cascade Control _____	10
Temperature Control _____	10
Terminal Connection _____	11
FCC-E Transducer _____	11
Wiring Diagrams _____	12

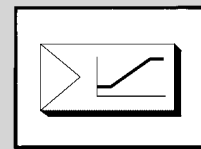

## Fume Cupboard Extraction with LABCONTROL TCU-LON II



### Applications

The main application area of the TCU-LON II digital controller is in laboratories. It finds here application as both a fume cupboard controller with a monitoring function as well as a room balance controller.

The LABCONTROL system with TCU-LON II controllers, modified to carry out customer-specific tasks, thus offers the perfect single-source system solution.

In air handling systems, where complex control processes play the major role and where a high degree of data integrity is necessary, control systems which communicate digitally have an advantage over analogue systems. For comparatively low investment, functionality can be considerably increased. In addition, the wiring effort is less, and thus the risk of wiring mistakes is considerably reduced.

With the LONWORKS® technology used by Trox, all information is exchanged over a 2-wire data cable which cannot be reversed in polarity. The LONWORKS® technology also allows the connection of sensors and actuators such as motion sensor, temperature sensors and room operating devices from other manufacturers. Standardised signals offer the greatest possible degree of flexibility.

The system's functions, stored in a database, guarantee complete clarity of the control networks constructed for many years. Extensions or modifications to the system are therefore effectively simplified.

Since technical control processes inside laboratories are many-sided and very complex, data pertaining to safety must be continually collected and monitored. This is done centrally with Building Management System (BMS). All data points come together here and can be documented and administered.

When using LABCONTROL with the TCU-LON II control unit, all of the controller data can be visualised and influenced centrally. This is a major difference from LON modules that do not allow any direct access to the controller, but only to the LON module.

The alarm messages concerning laboratory control can optionally be sent by text message to mobile telephones. Furthermore, remote access is possible using additional modules with which the control parameters can be changed or fault diagnosis can be made.

### The Main Advantages of the LONWORKS® Technology:

- All of the controllers can be addressed from a central service point
- All of the actual and set values can be requested centrally
- LON-supporting peripheral devices (motion sensors, I/O modules, etc.) can be incorporated in the system
- Possibilities for direct incorporation in the BMS
- Fault messages are passed on with details of the error source
- Alarm messages can be sent by additional devices directly to the necessary centre by text message (additional devices necessary)
- Remote access allow quick access to the system – flexible service at low cost and quick
- Configuration of the Trox TCU-LON II via Trox Plug-Ins

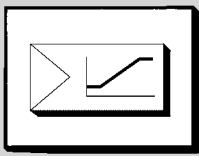

## Wiring effort for Conventional Analogue Technology

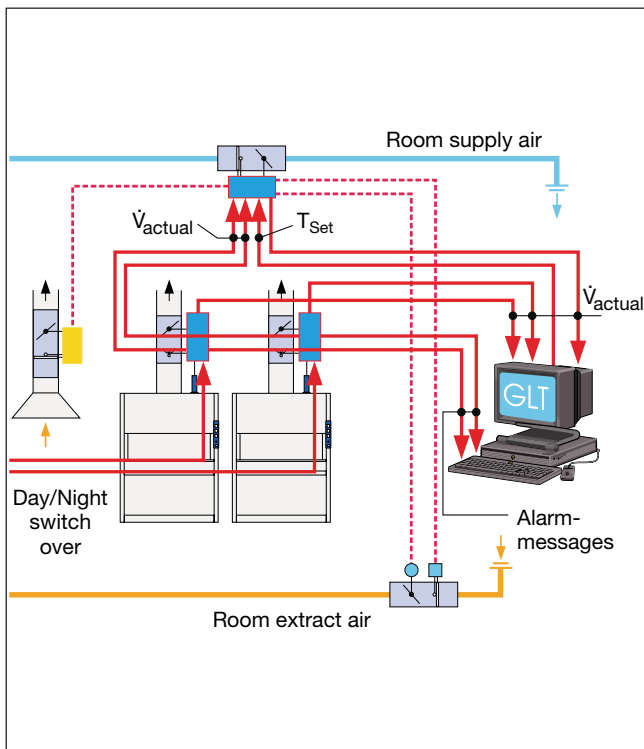

## Wiring effort for LON Technology

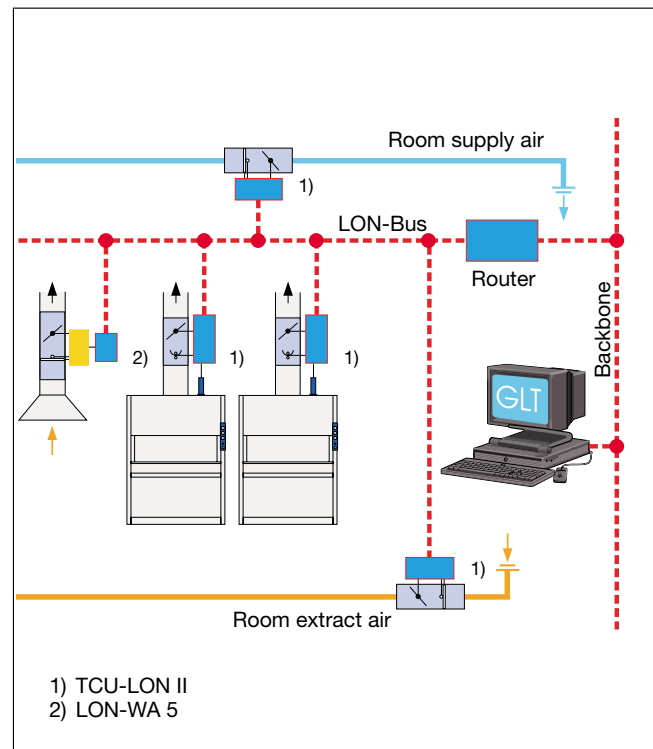

### Functional description

The TCU-LON II digital controller has been designed for demanding technical control tasks. The integrated LON interface allows complex exchanges of information. The large wiring effort at installation time often needed for analogue systems is thus reduced to a minimum.

The TCU-LON II digital controller contains, amongst other things, the Neuron<sup>®</sup> chip necessary for the LON technology, in which the software functions are stored. By means of this software, modified to fit the application, the TCU-LON II digital controller can perform a variety of control tasks.

The TCU-LON II contains a diaphragm pressure transducer to measure the actual volume flow in the form of a pressure difference. The effective pressure, from which the volume flow can be calculated, is measured on the static differential pressure principle. The differential pressure sensor in the volume flow control unit detects the effective pressure. This causes a deflection on the measurement diaphragm, which is recorded inductively and converted into a pressure linear voltage signal. Linearization of the volume flow is performed by the TCU-LON II. The measurement range depends on the volume flow controller. Since the controller is also used in areas with aggressive extraction, the transducer is additionally protected by inducting room air into the measurement tubing. For long-term stabilisation of the measured signal, automatic zero-point compensation is provided as standard. This allows exact measurement over long periods even if the effective pressure is low.

As well as the LON interface, two digital inputs and a relay output are available, so that, for example, alarm messages or switching of special functions may be realised conventionally.

Analogue controllers from other manufacturers may be included using the additional Trox LON-WA5 module. This allows such VAV controllers to be used in the LON network.

### Note:

The TCU-LON II controllers are supplied with the project-specific basic parameters. For complete function commissioning and system integration is necessary.

**We recommend that start-up be implemented by Trox service personnel.**

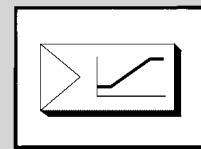

## Fume Cupboard Extraction Control

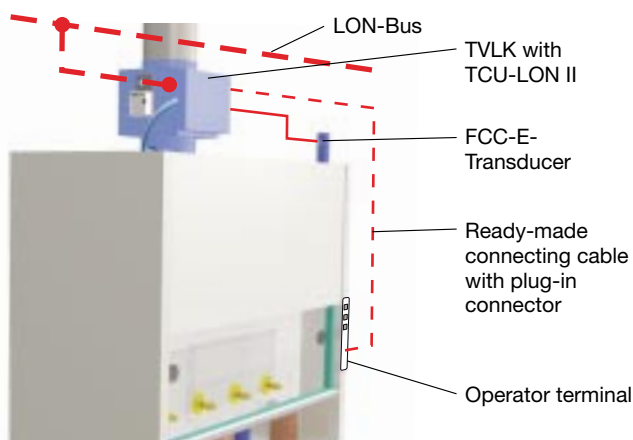

## Fume Cupboard Control with Movement Detector and Additional Switching Functions

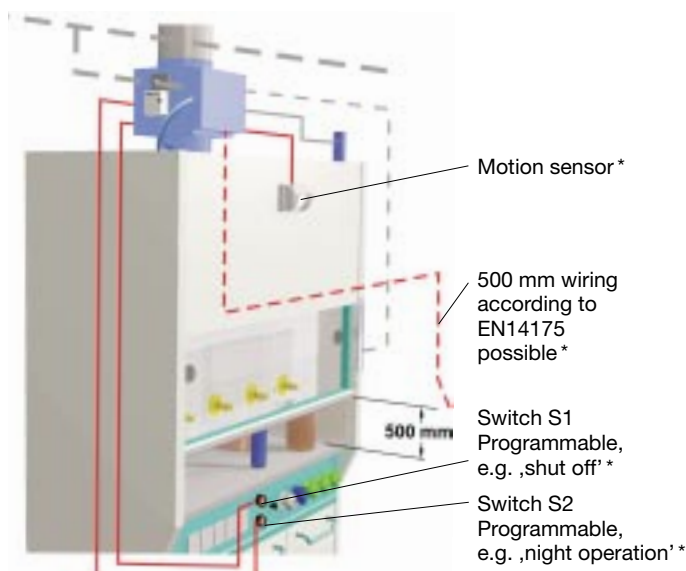

\* Altogether two options simultaneously utilizable

## Control Diagram Intake Velocity/Volume Flow

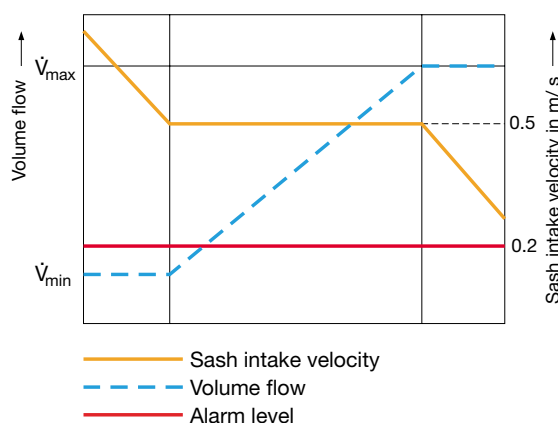

## Laboratory extraction control

The TCU-LON II control unit is mainly used for controlling fume cupboards with variable volume flows. This is done by intake velocity/volume flow cascade control. All requirements of DIN 12924, EN 14175, the British Standard (BS) and the ASHRAE standard are conformed to.

This controller offers the highest possible level of safety while remaining economical. For use as a fume cupboard controller, the TCU-LON II is combined with a Trox volume flow control device (e.g. TVLK). The unit consists of the TCU-LON II controller with an integrated function control and the volume flow control device with actuator and control damper blade. In addition, the FCC-E intake velocity transducer is delivered separately and mounted on the fume cupboard by the customer. This needs a bypass opening of 21 mm diameter. Also included in the delivery is an operator terminal for user operation of the controller.

The TCU-LON II controller unit controls the air intake velocity and the volume flow for a single fume cupboard. The FCC-E transducer measures intake velocity without contact, moving parts or wear. The sash window can be adjusted in its vertical plane and slid in its horizontal plane. Side openings for the connection of several fume cupboards are also possible. The measurement system records the intake velocity independently of the location of the opening.

Thermal loads inside of the cupboard do not affect measurement, but automatically lead to an increase in the volume flow and thus safe extraction of the heat.

The actual volume flow value is available as a digital LON signal. As a result the fume cupboard can be included in room air balance. Override switching can be performed by switch and relay, or LON signals can be sent to the controller. Intake velocity monitoring with both acoustic and visual alarms is integrated. For night operation, the acoustic alarm can be suppressed.

The following safety requirements for fume cupboards are conformed to:

- Control of intake velocity independently of the position of the control damper blade (by means of contact-free, wear-free recording of actual values), so horizontally sliding windows are also included in the control operation
- Fast recording of actual values
- Fast and stable control (response time  $\leq 3$  seconds)
- Maintenance of a minimum volume flow with sash window closed
- Limiting the maximum volume flow with fully opened sash window
- Automatic increase of the extraction air volume flow with high thermal loads
- Possibility of full air tight shut off
- Special operating modes can be switched in
- Can be integrated into the supply and extraction volume flow control of the laboratory taking simultaneity factors into account
- Automatic zero-point compensation and room air induction of the integrated diaphragm pressure transducer

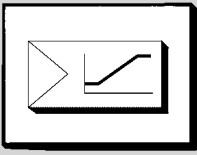

### Digital Inputs

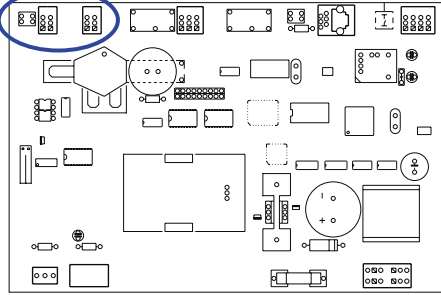

### Overview of Most Important Functions

#### Can be freely Configured for:

- Reduced operation mode, constant volume flow 1) \*
- Emergency operation (volume flow increase), constant volume flow 2) \*
- Shut off \*
- Fully opened \*
- Connection of a window contact (opened 500 mm) according to EN 14175
- Connection of a second volume flow monitoring

\* Operating modes can also be switched via LON

### Alarm contact (change-over contact)

LON

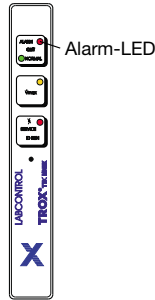
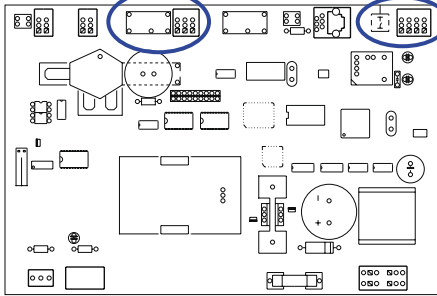

#### Alarm-Transmission via:

- LON and/or relay output
- The acoustic alarm time can be configured
- Monitoring modes: Volume flow and/or air intake velocity can be selected

#### Hardware Failure Message:

- Via LON
- Red LED flashing



$V_{max}$  button

#### $V_{max}$ Mode/Emergency Mode

- Increased volume flow can be adjusted with  $V_{max}$ -button, independent of the sash window position
- Can be set for limited times (1 to 999 min)
- Priority over all other operation modes

### Motion sensor

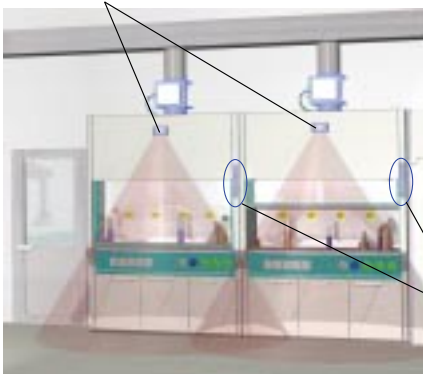

Operator terminal

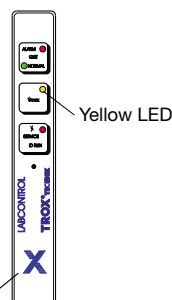

Yellow LED

#### Upon Request:

- When the fume cupboard is open, without movement in front of the fume cupboard: acoustic signal and flashing yellow LED (meaning: please close fume cupboard) and/or
- Independent of sash window position, without movement in front of the fume cupboard: reducing the air intake velocity from 0.5 to 0.3 m/s.



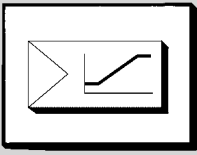

## Example of Inclusion of Simultaneity Factor GF in Room Control

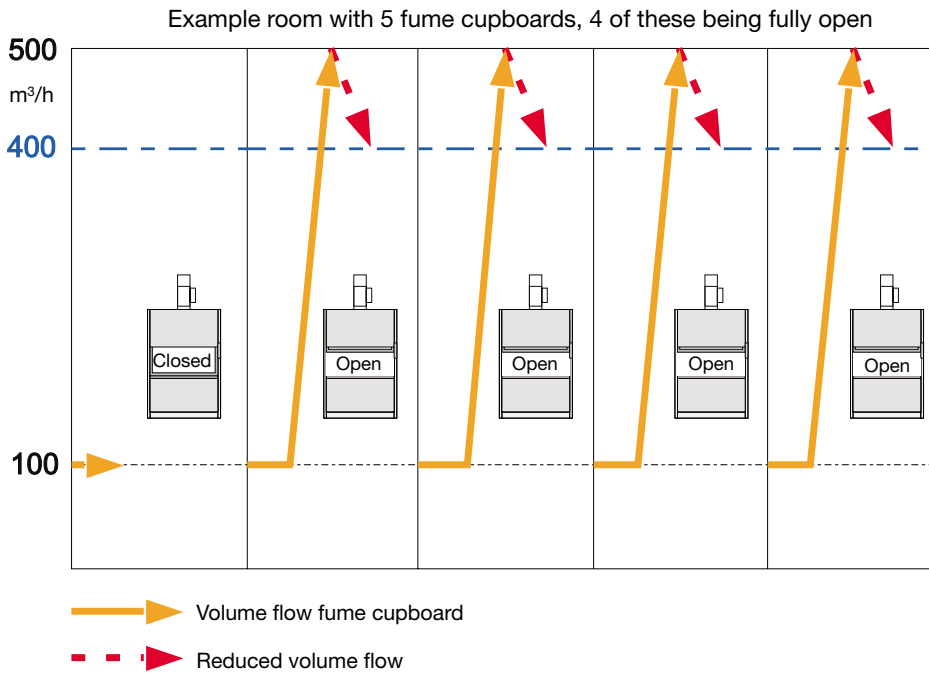

### Example

- Room with 5 fume cupboards,  $\dot{V}_{\max}$  fume cupboard = 500 m<sup>3</sup>/h,  $\dot{V}_{\max}$  fume cupboards total = 2500 m<sup>3</sup>/h
- At most 3 fully open fume cupboards simultaneously permitted  $\dot{V}_{\max}$  fume cupboards total = 1700 m<sup>3</sup>/h
- Also gets the fourth fume cupboard open, the TCU-LON II-Controller will reduce the total volume flow  $\dot{V}_{\text{fume cupboards total}}$  to 1700 m<sup>3</sup>/h, 400 m<sup>3</sup>/h per fume cupboard

The four fully opened fume cupboards give an alarm signal. For safety operation one cupboard must be closed.

## Room Control Considering the Simultaneity Factor SF

Large laboratory buildings are often operated in volume flow balance taking simultaneity factors into account for reasons of economics. The advantages of variable volume flow control can be fully utilised. This method is based on only a few of the fume cupboards being open at the same time. Most of the fume cupboards are assumed to be closed. The advantage of this procedure lies in the fact that both the duct system and the fans can have smaller dimensions. Until recently, however, this could lead to problematical situations which, thanks to the new LABCONTROL generation, are now a thing of the past.

It was previously necessary to carry out hydraulic balancing to ensure that the calculated air conditions were maintained in all areas. This is now checked by the room controller itself and corrected if necessary. This prevents

a GF = 1 being reached in areas which, for example, are near the fans (hydraulically good), which results in a GF of under the calculated value in other areas. It is difficult, of course, for laboratory users to find out which part of the laboratory is responsible for this displacement. Unallowable exceeding of the air balance is recognized by LABCONTROL and can be corrected by lowering the volume flow at the open fume cupboards. Laboratory areas in the vicinity are not negatively affected by this. The fume cupboard controller TCU-LON II generate an alarm at the operator terminal, alerting the user that the SF has been exceeded.

Moreover an alarm message can be transmit via LON and/or relay output to the BMS if the simultaneity factor is exceeded.

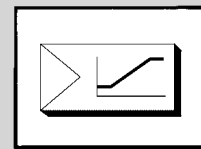

## Operator Terminal

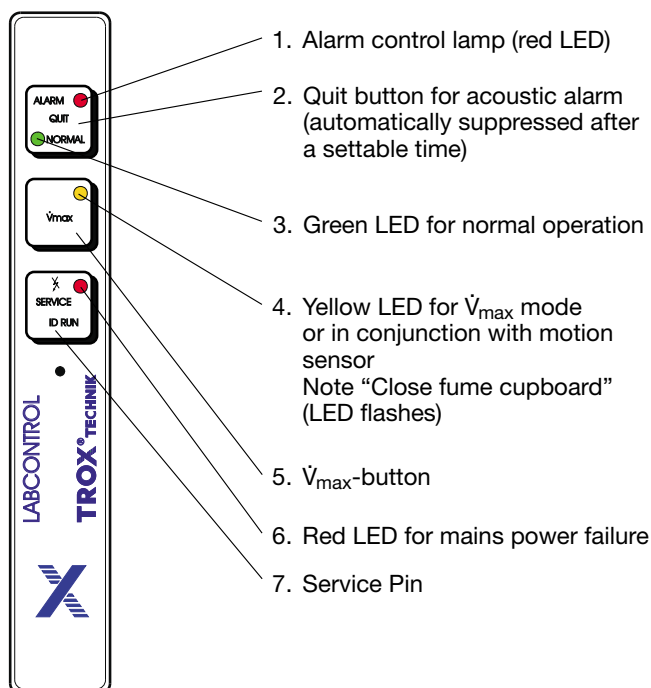

## General

The Trox TCU-LON II operator terminal indicates whether the safety of the fume cupboard is guaranteed. The volume flow and/or the intake velocity is monitored. This function monitoring is required under DIN 12924, Part 1 and is for the safety of the fume cupboard user.

The Trox LABCONTROL operator terminal has four control lamps (LEDs) that display the actual operation mode of the fume cupboard. There are two buttons for acoustic alarm suppression and for overriding  $\dot{V}_{\max}$  switching. If the specified conditions are not fulfilled to, alarm control lamp 1 lights up and an acoustic alarm sounds. Any power failure is indicated by the red, capacitor-buffered LED.

## Dimensions in mm

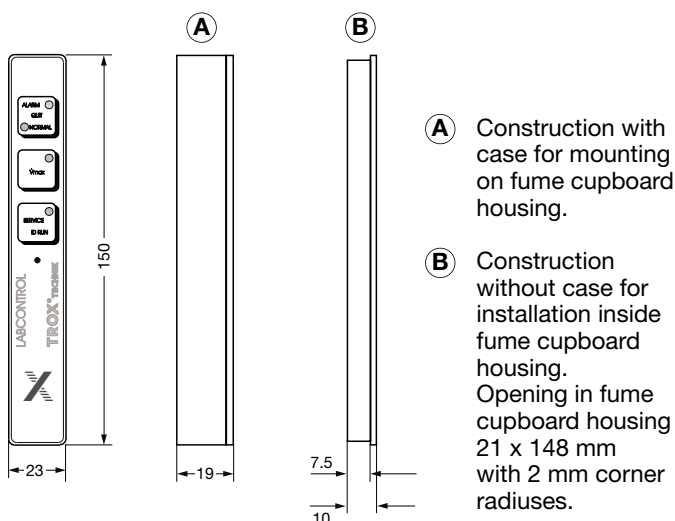

## Description, Operation

### 1. Alarm control lamp, red

If this control lamp is permanently lit, the actual volume flow and/or the air intake velocity is no longer in the safe range (acoustic alarm, standard duration 5 seconds, can be switched off with button 2 (Quit)). The red control lamp does not extinguish until the reason for the alarm has been eliminated.

Reasons for the alarm can be:

- Fully open sash window (with pure intake velocity monitoring)
- Failure of the fan or pressure drop in the ductwork

### Note:

If the alarm has not been eliminated after the sash window has been closed, please inform the service staff! A permanently flashing alarm LED indicates a hardware error.

### 2. Alarm button (Quit)

The acoustic alarm can be switched off with this button.

### 3. Function control lamp (green LED)

Permanently lit LED: controller in normal mode  
 BFlashing LED: special mode (e.g. night operation, complete shut-off)

### 4. $\dot{V}_{\max}$ control lamp (yellow LED)

The  $\dot{V}_{\max}$  control lamp lights up when the controller is working in  $\dot{V}_{\max}$  mode. If the volume flow required by  $\dot{V}_{\max}$  mode is not sufficient there is a visual and an acoustic alarm.

Flashing LED in conjunction with movement sensors means: "Please close fume cupboard"

### 5. $\dot{V}_{\max}$ button

This button can be used to manually increase the volume flow to the maximum  $\dot{V}_{\max}$  value at any time (keep the button pressed down until yellow control lamp 4 lights up). Press the button again to return to normal operation mode. If a time limit has been set, the yellow LED lights up after the set time and the normal mode is resumed.

If the  $\dot{V}_{\max}$  button has been deactivated by the software, the  $\dot{V}_{\max}$  is not raised, the LED does not light up.

### 6. Mains control lamp (red LED)

This control lamp flashes if the power supply fails (approx. 12 hours maintenance-free capacitor buffering). In this case, there is no other alarm message.

### 7. LON-ID service Pin

This button is used to generate the TCU-LON II Neuron ID in the LON network.

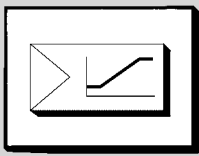

## Room Pressure/Room Balance Cascade Control

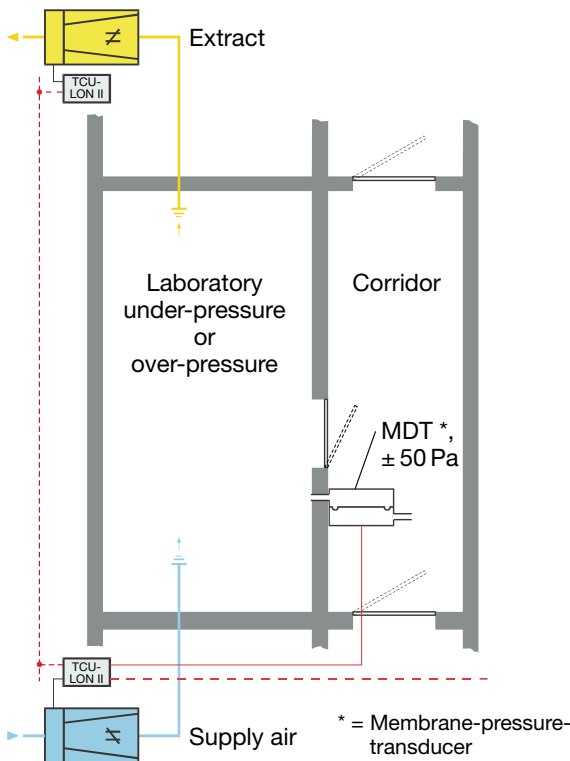

## Room Pressure/Room Balance Cascade Control

Instead of having only a room balance control, it is possible to make a combination between a room balance and room pressure control. In this case all individual extract air volume flow rates are recorded and communicated to the room controllers. The room controllers themselves balance the necessary room supply and extract air. Additionally the recorded room pressure is connected to the room supply controller in cascade. If there is a difference between actual room pressure and the specified required value a supply-extract volume flow difference shift will compensate it.

In contrast to room pressure control only, this process takes the room volume flow balance into account, such that this system works stable in operation with changing openings as doors and no extreme damper blade positions occur. The desired room under-pressure or over-pressure is thus maintained at all times.

In contrast to constant volume flow difference the excess flow can be increased when doors are opened without loss of convenience.

A change over between under and over pressure can be configured as well.

## Room Pressure, Room Balance and Room Temperature Control

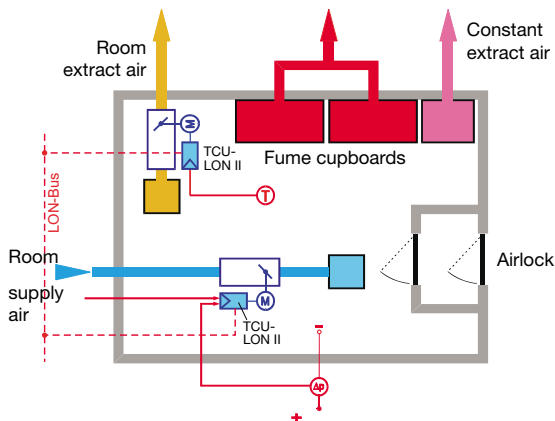

## Temperature Control

### Volume Flow Shift

A temperature control can be realised in a number of ways. The volume flow rates are varied dependant of the temperature signal, without room pressure changing.

Following variants are practically:

1. Volume flow rate influence with temperature control by TCU-LON II, direct connection of temperature signal (see example). Switch-over for summer/winter integrated and can be controlled.
2. Changing of volume flow by an external temperature controller with 0 to 10 VDC signal, or as LON order.

### Reheater Control

The TCU-LON II can be operated with a VVS controller with an integral reheater. Here, the TCU-LON II controls the reheater valve with a LON actuator (supplementary option).

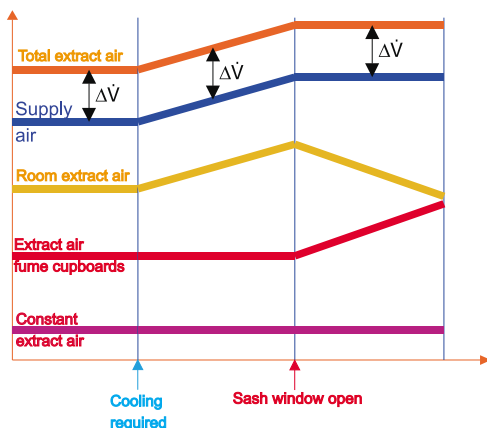

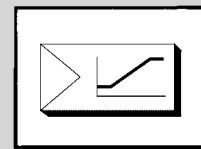

## Terminal Connection

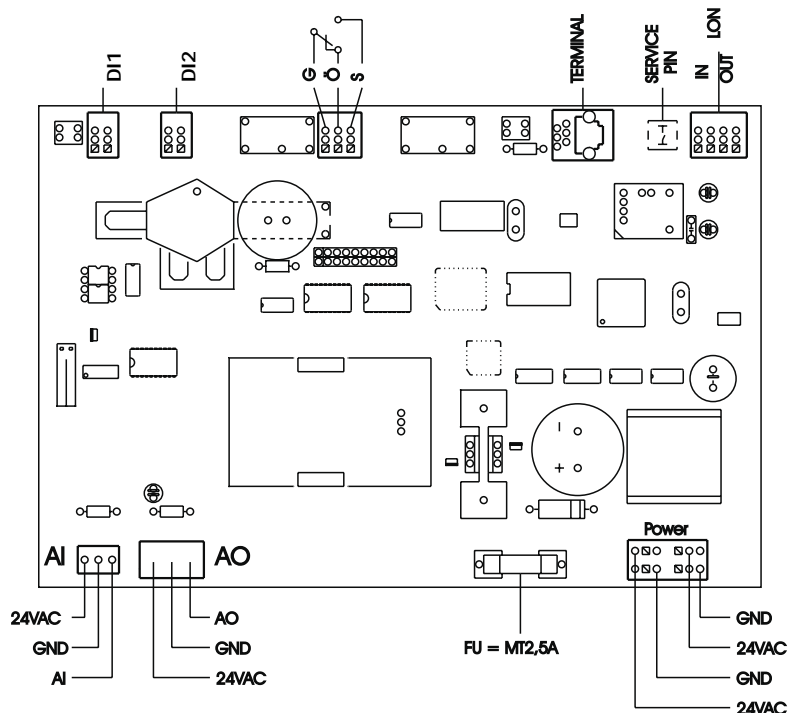

### Nomenclature

GND	Signal Ground
24VAC	Supply voltage
AI	Analog input
AO	Analog output
LON IN	Input LON-Bus
LON OUT	Output LON-Bus

Terminal	Connecting socket for operator terminal
DI1	Switch input for additional functions
DI2	Switch input for additional functions
FU	MT 2.5 A fuse
G	Ground
O	Break contact
S	Closing contact

## Wiring

The device control components are factory-wired. When a 24 VAC supply is required, safety transformers (EN 60742) are to be used.

If several controllers are connected to a 24 VAC supply, it is important that a common zero wire is defined and not altered.

Project-related standard wiring schematics for the LABCONTROL components will be provided by Trox.

## Intake Velocity Control

The FCC-E transducer is mounted on the fume cupboard and connected up according to the installation instructions.

## Override Control

Room control of variable volume flow or air intake velocity can be overridden by potential-free contacts on the customer side.

Technical data:	
Supply voltage	24 VAC, $\pm 5\%$ , 50 Hz
Power consumption	20 VA
Temperature range	10 to 40 °C
Type of protection	IP 20

## FCC-E-Transducer

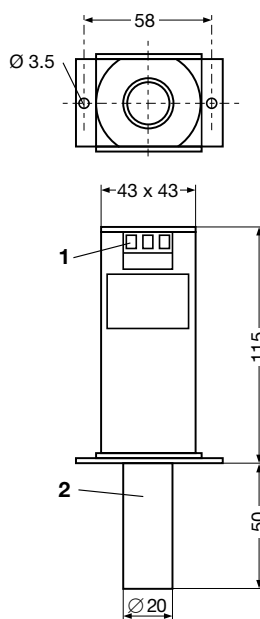

- 1 Connection terminals
- 2 Sensor tube

Technical Data:
- Power supply 24 VAC
$\pm 5\%$ , 50 Hz
- Measurement range 0.1 to 1 m/s
- Output signal 2 to 10 VDC
- Type of protection IP 20

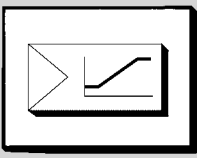

### Wiring Diagram for Fume Cupboard Control, Code TMA, Operating Mode FH <sup>1)</sup>

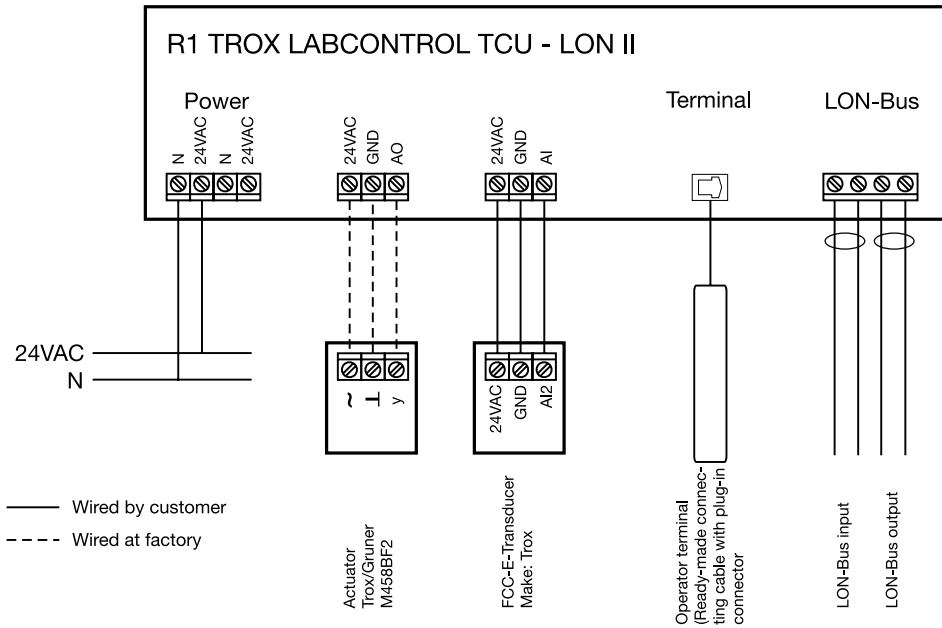

### Wiring Diagram for Room Control, Code TMA, Operating Mode RE/RS/PS <sup>1)</sup>

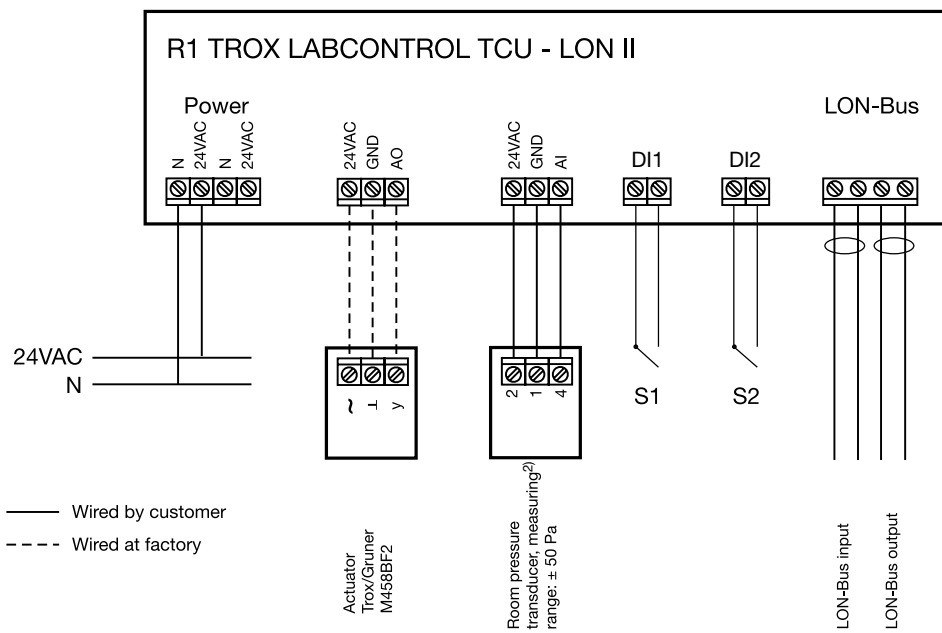

- 1) Operation modes:  
 FH = Fume cupboard control  
 RE = Room extract air  
 RS = Room supply air  
 PS = Room pressure control with supply air, incl. ± 50 Pa-Transducer
- 2) Room pressure control integrated (only PS)